

DEPARTMENT OF THE ARMY TECHNICAL MANUAL

OPERATOR AND ORGANIZATIONAL
MAINTENANCE MANUAL

PUMP, CENTRIFUGAL
FRESH WATER; GASOLINE DRIVEN
2 WHEEL MOUNTED; 4 IN
500 GPM, 30 FT HEAD
(CARVER MODEL K400S) FSN 4320-810-7311
(LESS ENGINE)

This copy is a reprint which includes current
pages from Changes 1 through 5

HEADQUARTERS, DEPARTMENT OF THE ARMY
MARCH 1961

SAFETY PRECAUTIONS

Before Operation

When lifting the pumping unit from the bed of the carrier, be sure that the lifting device has a lifting capacity of at least 2,000 pounds. Do not allow the pumping unit to swing while suspended. Failure to observe this warning may result in damage to the unit or severe injury to personnel.

When the unit is operated in an inclosed area, exhaust gases must be piped to the outside. Continued breathing of exhaust gases is dangerous and may be fatal.

Do not smoke or use an open flame when servicing the batteries. Batteries generate hydrogen, a highly explosive gas.

Do not fill the fuel tank while the engine is in operation. Gasoline spilled on a hot engine may explode and cause serious injury to personnel. When filling the fuel tank always provide a metal-to-metal contact between the container and the fuel tank. This will prevent a spark from being generated as fuel flows over the metallic surface.

Be extremely careful when using a bromochloromethane fire extinguisher in an inclosed area. A poisonous gas is generated by the contact of bromochloromethane with a heated metallic surface. Provide adequate ventilation before entering an inclosed area where bromochloromethane has been used.

During Operation

When the unit is operated in an inclosed area, exhaust gases must be piped to the outside. Continued breathing of exhaust fumes is dangerous and may be fatal.

Be extremely careful when using a bromochloromethane fire extinguisher in an inclosed area. A poisonous gas is generated by the contact of bromochloromethane and a heated metallic surface. Provide adequate ventilation before entering an inclosed area where bromochloromethane has been used.

After Operation

Do not smoke or use an open flame when servicing the batteries. Batteries generate hydrogen, a highly explosive gas.

Be extremely careful when using a bromochloromethane fire extinguisher in an inclosed area. A poisonous gas is generated by the contact of bromochloromethane and a heated metallic surface. Provide adequate ventilation before entering an inclosed area where bromochloromethane has been used.

Changes in Force: C1, C3, C4, and C5

CHANGE

HEADQUARTERS
DEPARTMENT OF THE ARMY
WASHINGTON, D.C., 10 October 1990

NO. 5

Operator and Organizational Maintenance Manual

PUMP, CENTRIFUGAL, FRESHWATER; GASOLINE ENGINE DRIVEN;
2-WHEEL MOUNTED; 4-IN, 500 GPM, 30-FT. HEAD
(CARVER MODEL K400S) FSN 4320-810-7311 (LESS ENGINE)

Approved for public release; distribution is unlimited

TM 5-4320-215-12, 9 March 1961, is changed as follows:

Page 9, paragraph 10(c), add the following note:

NOTE

The 6TN and 6TL batteries can be mixed or matched. However, maintenance-free batteries cannot be mixed or matched with military batteries.

By Order of the Secretary of the Army:

CARL E. VUONO
General, United States Army
Chief of Staff

Official:

THOMAS F. SIKORA
Brigadier General, United States Army
The Adjutant General

DISTRIBUTION:

To be distributed in accordance with DA Form 12-25E, (qty rqr block no. 1414).

TECHNICAL MANUAL
Operator and Organizational Maintenance Manual
PUMP, CENTRIFUGAL: FRESH WATER; GASOLINE DRIVEN:
2 WHEEL MOUNTED; 4.IN.; 500 GPM, 30 FT HEAD (CARVER MODEL K400S)
FSN 4320-810-7311 (LESS ENGINE)

TM 5-4320-215-12 }
CHANGES No. 1 }

HEADQUARTERS,
DEPARTMENT OF THE ARMY
WASHINGTON 25, D. C., 17 December 1962

TM 5-4320-215-12, 9 March 1961, is changed as follows:

instructions outlined on DA Form 2258, which is attached on or near the operator's controls.

Page 3. Paragraph 1d. (Superseded)

Page 10. Paragraph 12a, line 2. Delete "operator's daily" and substitute: daily preventive maintenance.

d. Report all deficiencies in this manual on DA Form 2028. Submit recommendations for changes, additions, or deletions to the Commanding Officer, U. S. Army Mobility Support Center, ATTN: SMOMS-MS, P. O. Box 119, Columbus 16, Ohio. Direct communication is authorized.

Page 11. Paragraph 17a, line 1. Delete "before-operation" and substitute: daily preventive maintenance.

Page 3. Paragraph 2.

Page 11. Paragraph 19a(2), line 1. Delete "during-operations" and substitute: daily preventive maintenance.

2. Record and Report Forms (Superseded)

Page 15. Figure 8. Engine stopping instructions. Delete "NOTE: PERFORM AFTER OPERATION SERVICES (PAR. 31)."

a. DA Form 2258 (Depreservation Guide of Engineer Equipment).

Page 23. Paragraph 30.

b. For other record and report forms applicable to operator and organizational maintenance, refer to TM 38-750.

30. General (Superseded)

Note
Applicable forms, excluding Standard Form 46, which is carried by the operator, shall be kept in a canvas bag mounted on the equipment.

To insure that the centrifugal pump is ready for operation at all times, it must be inspected systematically, so that defects may be discovered and corrected before they result in serious damage or failure. The necessary Preventive Maintenance Services to be performed are listed and described in paragraphs 31 and 33. The item numbers indicate the sequence of minimum inspection requirements. Defects discovered during operation of the unit shall be noted for future correction, to be made as soon as operation has ceased. Stop operation if a deficiency is noted during operation which would damage the equipment if operation were continued. All deficiencies and shortcomings will be recorded, together with the corrective action taken, on DA Form 2404 at the earliest possible opportunity.

Page 9. Paragraph 7b, line 4. Delete "(fig. 1)" and substitute: (fig. 2).

Page 9. Paragraph 8a, lines 2 and 3. After possible. Delete "Remove any protective material that may be on the unit."

Page 9. Paragraph 8b. (Superseded)

Page 23. Paragraph 31.

b. Before the pump is placed in operation, depreservation will be accomplished in accordance with TAGO 7365A-Dec

PREVENTIVE MAINTENANCE SERVICES

DAILY

TM5-4320-215-12

CARVER MODEL K400S

CENTRIFUGAL PUMP

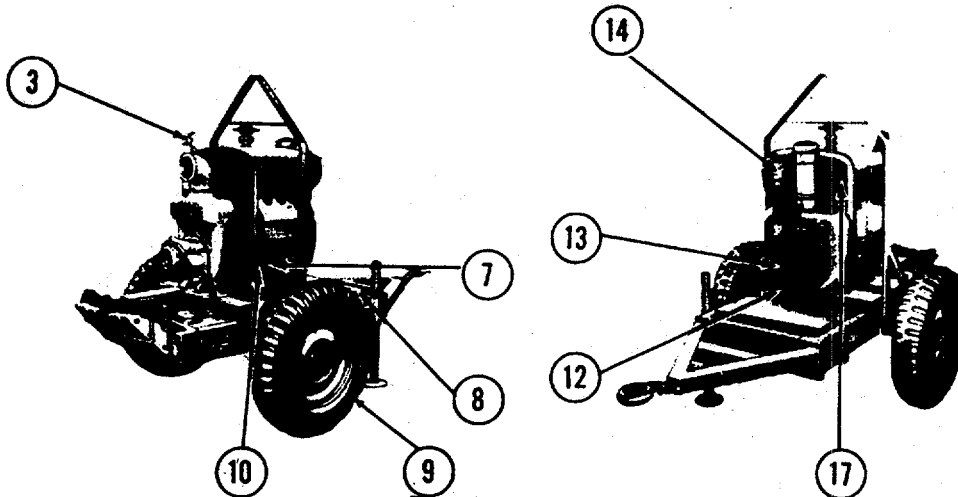

LUBRICATE IN ACCORDANCE WITH CURRENT LUBRICATION ORDER

ITEM	PAR REF
3	<u>FIRE EXTINGUISHER.</u> Inspect for broken seal.
7	<u>FUEL STRAINER.</u> Inspect for leaks. Clean sediment bowl and screen. (Weekly)
8	<u>BATTERIES.</u> Inspect cables by hand for tightness. Inspect for leaks and corrosion. Fill to 3/8 inch above the plates. In freezing weather, run the engine a minimum of 1 hour after adding water. Clean vent hole in filler caps. (Weekly)
9	<u>TIRES AND WHEELS.</u> Check tires for correct pressure (45 psig). Inspect tires for excessive wear, cuts, breaks, imbedded foreign matter, and missing valve caps. (Weekly)
10	<u>OIL LEVEL GAGE.</u> Check engine oil level. Add oil as indicated by level gage. Reference current LO 5-2805-209-12.
12	<u>BELTS.</u> Inspect the belt for tension. Proper deflection is 1 inch midway between pulleys. (Weekly)

Figure 10. (Superseded) Daily preventive maintenance services.

ITEM		PAR REF
13	<u>SCREEN.</u> Inspect screen for accumulation of foreign matter. Clean a dirty screen.	
14	<u>OIL FILTER ASSEMBLY.</u> Inspect for leaks.	
17	<u>CONTROLS AND INSTRUMENTS.</u> Inspect the controls and instruments for damage. With the unit operating, normal readings are as follows: Ammeter; slightly charge, tachometer; 2,200 rpm, oil pressure gage; <u>ON.</u>	
	<u>NOTE 1. OPERATION.</u> During operation observe for any unusual noise or vibration.	

EMC 4320--215--12/10.1

Figure 10. Continued.

PREVENTIVE MAINTENANCE SERVICES

QUARTERLY

TM5-4320-215-12

CENTRIFUGAL PUMP

CARVER MODEL K400S

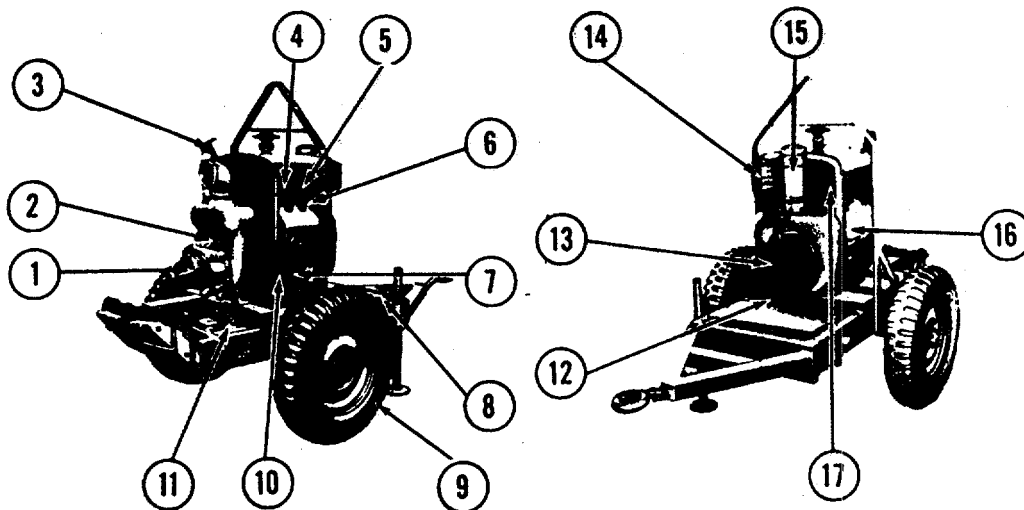

ITEM	LUBRICATE IN ACCORDANCE WITH CURRENT LUBRICATION ORDER	PAR REF
1	<u>VALVES.</u> Inspect the suction valve and gasket for damage and deterioration. Inspect for improper operation.	
2	<u>PUMP.</u> Inspect for insecure mounting, leaks, and misalignment. Inspect the suction flange and suction head for defective gaskets.	
3	<u>FIRE EXTINGUISHER.</u> Inspect for broken seal. Weigh the new and fully charged monobromotrifluoromethane fire extinguisher and enter on inspection record. Weigh every 3 months there after. If the gross weight has decreased 4 ounces or more replace cylinder.	
4	<u>FUEL PUMP AND HAND PRIMER.</u> Inspect for leaks.	
5	<u>CARBURETOR AND LINKAGE.</u> Inspect for insecure mounting, leaks, and improper operation.	
6	<u>SPARK PLUGS.</u> Inspect spark plugs for cracked porcelain. Correct gap is 0.025 inch. Proper torque is 25-30 foot pounds.	
7	<u>FUEL STRAINER.</u> Inspect for insecure mounting and leaks.	

Figure 10.1. (Added) Quarterly preventive maintenance services.

ITEM		PAR REF
8	<u>BATTERIES.</u> Remove cables from battery posts, inspect for corrosion and clean.	48
9	<u>TIRES AND WHEELS.</u> Inspect tires for excessive wear, cuts, breaks, imbedded foreign matter, and missing valve caps. Inspect lug nuts for tightness.	60
10	<u>OIL LEVEL GAGE.</u> Check engine oil level. Add oil as indicated by level gage. Reference current LO 5-2805-209-12.	
11	<u>FUEL TANK AND GAGE.</u> Inspect for leaks and insecure mounting.	
12	<u>BELTS.</u> Inspect the belt for improper tension and worn or frayed condition. Proper deflection is 1 inch midway between pulleys.	
13	<u>AIR SHROUD AND SCREEN.</u> Inspect for insecure mounting and obstructed air passage.	
14	<u>OIL FILTER ASSEMBLY.</u> Inspect for insecure mounting and leaks.	
15	<u>AIR CLEANER.</u> Inspect for insecure mounting, contaminated oil, and level of the oil. Oil should be to level mark. Reference current LO 5-2805-209-12.	
16	<u>CRANKCASE BREATHER.</u> Inspect for insecure mounting and clogged condition. Clean a dirty breather.	
17	<u>CONTROLS AND INSTRUMENTS.</u> Inspect the controls and instruments for damage. With the unit operating, normal readings are as follows: Ammeter; slightly charge, tachometer; 2,200 rpm, oil pressure gage; <u>ON</u> .	
	<u>NOTE 1. OPERATIONAL TEST.</u> During operation observe for any unusual noise or vibration.	
	<u>NOTE 2. ADJUSTMENTS.</u> Make all necessary adjustments during operational test.	

EMC 4320-215-12/10.2

Figure 10.1. Continued.

31. Daily Preventive Maintenance Services

(Superseded)

This paragraph contains an illustrated tabulated listing of preventive maintenance services which must be performed by the operator. Daily services retain the same item number used in the Quarterly Preventive Maintenance Services. Therefore, Daily Preventive Maintenance Services may not be numbered consecutively but should be performed in the numerical sequence as shown to insure complete coverage. Refer to figure 10 for the Daily Preventive Maintenance Services.

Page 23. Paragraph 32. (Rescinded)

Page 26. Paragraph 33.

33. Quarterly Preventive Maintenance Services

(Superseded)

a. This paragraph contains an illustrated tabulated listing of Preventive Maintenance Services which must be performed by Organizational Maintenance personnel at quarterly intervals. A quarterly interval is equal to 3 calendar months, or 250 hours of operation, whichever occurs first.

b. The item numbers are listed consecutively and indicate the sequence of minimum requirements. Refer to Figure 10.1 for the Quarterly Preventive Maintenance Services.

Page 53. Paragraph 67.

67. Preparation of Equipment for Shipment

(Superseded)

a. *General.* Detailed instructions for preparation of the pumping unit for domestic shipment are outlined within this paragraph. Preservation will be performed in a sequence that will not require operation of previously preserved components.

b. *Inspection.* Examine the pumping unit for any unusual conditions such as damage, rusting, accumulation of water, and pilferage. Inspect in accordance with steps outlined in the Quarterly Preventive Maintenance Services (par. 33).

c. *Cleaning and Drying.* Prior to application of any preservatives, clean and dry the pumping unit by an approved method. Approved methods of cleaning and drying, types of preservatives, and methods of application are described in TM 5-38-230.

d. *Painting.* Paint all surfaces where the paint has been damaged or removed. Refer to TB ENG-60 for detailed cleaning and painting instructions.

e. *Depreservation Guide.* Prepare a DA Form 2258, "Depreservation Guide of Engineer Equipment," concurrently with preservation of the pumping unit. Outline any peculiar requirements in the blank spaces provided. Place the Depreservation Guide in a waterproof envelope marked "Depreservation Guide" and fasten to the pumping unit in a conspicuous location on or near the operator's controls.

f. *Fuel Tank.* If the fuel tank is empty, fog or spray with preservative oil, type P-10, grade 2, conforming to Specification MILL-L21260. Otherwise, it is not necessary to drain or preserve the fuel tank.

g. *Batteries and Cables.* Disconnect the battery cables and secure with tape or twine in such a manner as to assure that they will not come in contact with the battery terminals during shipment. Batteries shall be shipped filled and fully charged in the battery box provided on the pumping unit.

h. *Air Cleaner.* Remove, drain, clean, and reinstall the air cleaner. Attach a tag to the air cleaner, indicating that the air cleaner has been drained. Seal the opening into the air cleaner with class 1, type III, pressure-sensitive tape conforming to specification PPP-T60.

i. *Lubrication System.* Check the lubrication system. If level is below operating level, fill to proper level with lubricant specified on the current Lubrication Order.

j. *Exposed Surfaces.* Coat exposed machined ferrous-metal surfaces with preservative type P-6, conforming with Specification MIL-C11796. If preservative is not available, use GAA grease as specified on the current Lubrication Order.

k. *Sealing of Openings.* Seal all openings that will permit the direct entry of water into the interior with class I, type III, pressure-sensitive tape conforming to Specification PPP-T-60.

l. *Pneumatic Tires.* The tires shall be inflated to their normal operating pressure.

AGO 7365A

m. Pumps. Spray interior of the pumping unit with type P-3 preservative oil, conforming to Specification MILC-16173, except preservative oil type P-14, conforming to Specification MILC-10382, shall be used for pumping units used in portable water systems.

n. Tools and Publications. Place tools and publications in the toolbox and fasten securely with metal banding or spot welding to prevent pilferage.

o. Marking. Marking shall conform to MILSTD-129.

Page 53. Paragraph 69.

69. Preparation of Equipment for Storage
(Superseded)

a. General. Limited Storage is defined as storage not to exceed 6 months. Refer to AR 743-505. Detailed instructions for preservation of pumping unit for limited storage are as outlined in paragraph 67, with the following exceptions:

b. Fuel Tank. The fuel tank shall be sprayed with type P-10 preservative: conforming to Specification MIL-L-21260 for limited storage.

c. Air Cleaner. Draining the air cleaner will not be required.

d. Pneumatic Tires. If the pumping unit is blocked up in storage so that all weight is removed from the tires, the tires shall be deflated to two-thirds their operating pressure.

Page 53. Paragraph 70b. (Superseded)

b. Quarterly Preventive Maintenance Services. The requirements as outlined on the "Quarterly Preventive Maintenance Services" shall be performed when the equipment is initially placed in limited storage and every 90 days thereafter. Required maintenance will be performed promptly to insure that the equipment is mechanically sound and ready for use.

Page 54. Paragraph 70c. (Superseded)

c. Operation. Operate equipment in limited storage long enough to bring it up to operating temperature and insure complete lubrication of all bearings, gears, and the like, in accordance with the scheduled interval contained in AR 743-505. Equipment must be serviced and in satisfactory operating condition before it is operated.

Page 55. Paragraph 3. After TM 9-2851, Painting Instructions for Field Use. (Added)

TB ENG 60 Preservation and Painting of Serviceable Corps of Engineers Equipment.

Paragraph 4. Delete "AR 700-38, Unsatisfactory Equipment Report" Paragraph 4. After TM 9-6140-200-5, Storage Batteries, Lead-Acid Type. (Added)

TM 38-230 Preservation, Packaging, and Packing of Military Supplies and Equipment.

TM 38-750 The Army Equipment Record System and Procedures.

Page 57. APPENDIX II. MAINTENANCE ALLOCATION (Superseded)

**APPENDIX II
MAINTENANCE ALLOCATION CHART**

Section I. INTRODUCTION

1. General

This Appendix contains explanations of all maintenance and repair functions authorized the various echelons. Section II contains the Maintenance Allocation Chart.

2. Maintenance

Maintenance is any action taken to keep material in a serviceable condition or to restore it to serviceability when it is unserviceable. Maintenance of materiel includes the following:

a. Service. To clean, preserve, and replenish fuel and lubricants.

b. Adjust. To regulate periodically to prevent malfunction.

c. Inspect. To verify serviceability and detect incipient electrical or mechanical failure by scrutiny.

d. Test. To verify serviceability and detect incipient electrical or mechanical failure by use of special equipment such as gages, meters, and the like.

e. Replace. To substitute serviceable assemblies, subassemblies, and parts for unserviceable components.

f. Repair. To restore an item to serviceable condition through correction of a specific failure or unserviceable condition. This function includes, but is not limited to, inspecting, cleaning, preserving, adjusting, replacing, welding, riveting, and straightening.

g. Aline. To adjust two or more components of an electrical system so that their functions are properly synchronized.

h. Calibrate. To determine, check, or rectify the graduation of an instrument, weapon, or weapons system, or components of a weapons system.

i. Overhaul. To restore an item to completely serviceable condition as prescribed by serviceability standards developed and published, by heads of technical services. This is accomplished through employment of the technique of "Inspect and Repair Only as Necessary" (IROAN). Maximum utilization of diagnostic and test equipment is combined with minimum disassembly of the item during the overhaul process.

3. Explanation of Columns

a. Functional Group. The functional group is a numerical group set up on a functional basis. The applicable Functional Grouping Indexes (obtained from the Corps of Engineers Functional Grouping Indexes) are listed in the MAC in the appropriate numerical sequence. These indexes are normally set up in accordance with their function and proximity to each other.

b. Components and Related Operation. This column contains the Functional Grouping Index heading, subgroup heading, and a brief description of the part starting with the noun name. It also designates the operations to be performed such as service, adjust, inspect, test, replace, repair, and overhaul.

c. Echelons of Maintenance. This column contains the various echelons of maintenance by number designation. An "X" placed in the appropriate echelon column in line with an indicated maintenance function authorizes that echelon to perform the function. The "X" indicates the lowest echelon responsible for performing the function, but does not necessarily indicate parts stockage at that level. Higher echelons are authorized to perform the indicated functions of lower echelons.

d. Remarks. This column lists specific maintenance functions, special tools, cross-references, instructions, and the like pertinent to the operation being performed.

Section II. MAINTENANCE ALLOCATION CHART

Functional group	Components and related operation	Echelons of maintenance					Remarks
		1	2	3	4	5	
01	ENGINE						
0100	ENGINE ASSEMBLY						
	Engine, Gasoline						
	Service.....	X					
	Inspect.....	X					
	Test.....		X				
	Replace.....		X				
	Repair.....			X			
	Overhaul.....				X		
0101	CRANKCASE, BLOCK, CYLINDER HEAD						
	Block Assembly, Engine						
	Replace.....				X		
	Repair.....				X		
	Crankcase Assembly, Engine						
	Replace.....				X		
	Repair.....				X		
	Head Assembly, Cylinder						
	Replace.....		X				
0102	CRANKSHAFT						
	Crankshaft Assembly						
	Replace.....				X		
	Bearing, Roller						
	Replace.....				X		
	Plate Assembly, Main Bearing						
	Replace.....				X		
0103	FLYWHEEL ASSEMBLY						
	Flywheel Assembly						
	Replace.....		X				
	Repair.....			X			Ring Gear
0104	PISTONS, CONNECTING RODS						
	Piston Assembly, Internal Combustion Engine						
	Replace.....				X		
	Ring Set, Piston						
	Replace.....				X		
	Rod Assembly, Connecting						
	Replace.....				X		
	Bearing, Sleeve						
	Replace.....				X		
0105.1	VALVES						
	Cap, Valve Stem						
	Replace.....			X			
	Guide, Valve						
	Replace.....			X			
	Retainer, Valve Spring Seat						
	Replace.....			X			
	Seat, Valve Spring						
	Replace.....			X			
	Spring, Helical, Compression						
	Test.....			X			
	Replace.....			X			
	Valves and Inserts						
	Replace.....			X			
	Repair.....			X			Reface

Functional group	Components and related operation	Echelons of maintenance					Remarks
		1	2	3	4	5	
0105.2	ROCKER ARMS, TAPPETS						
	Lifter, Valve						
	Adjust		X				
	Replace				X		
0105.3	CAMSHAFTS						
	Camshafts, Engine						
	Replace				X		
0105.5	TIMING GEARS						
	Cover Assembly						
	Replace			X			
	Gear, Helical						
	Replace			X			
	Shaft, Idler Gear						
	Replace			X			
0106.1	OIL PUMP						
	Pump Assembly, Oil						
	Replace			X			
	Repair			X			
0106.2	OIL FILTERS						
	Filter, Oil						
	Service	X					
	Replace		X				
0106.5	CRANKCASE VENTILATION						
	Breather, Oil Filler Tube						
	Service		X				
	Replace		X				
	Pipe, Oil						
	Replace		X				
	Strainer, Sediment						
	Service		X				
	Replace		X				
0106.6	OIL PANS, LINES, LEVEL GAGE						
	Cover, Oil Pan						
	Replace			X			
	Gage, Oil Level, Bayonet						
	Replace	X					
	Line Assembly, Oil						
	Replace		X				Fabricate
	Nozzle, Oil Spray						
	Replace			X			
	Pan, Oil						
	Replace			X			
	Plate, Cover						
	Replace			X			
0108	MANIFOLDS						
	Manifold, Upper Branch						
	Replace		X				
0111.1	HAND CRANKING DEVICES						
	Clamp, Hand Crank						
	Replace		X				
03	FUEL SYSTEM						
0301	CARBURETOR						
	Carburetor, Float						
	Adjust		X				
	Replace		X				
	Gasket, Bowl To Body						
	Replace		X				

Functional group	Components and related operation	Echelons of maintenance					Remarks
		1	2	3	4	5	
0302.4	FUEL PUMP, GASOLINE						
	Pump, Fuel						
	Test.....		X				
	Replace.....		X				
0304	AIR CLEANER						
	Air Cleaner, Carburetor						
	Service.....	X					
	Replace.....		X				
0306	TANKS, LINES, FITTINGS						
	Line Assembly, Fuel						
	Replace.....		X				Fabricate
	Tank, Gasoline						
	Service.....	X					
	Replace.....		X				
	Repair.....			X			
0308	ENGINE SPEED GOVERNOR						
	Governor, Gasoline Engine						
	Adjust.....		X				
	Replace.....		X				
	Repair.....			X			
0308.4	GOVERNOR CONTROLS						
	Control Assembly, Governor						
	Adjust.....		X				
	Replace.....		X				
0309	FUEL FILTERS						
	Strainer, Sediment						
	Service.....	X					
	Replace.....		X				
0311	PRIMING SYSTEM						
	Primer Assembly						
	Replace.....		X				
	Repair.....		X				
0312	ACCELERATOR, THROTTLE OR CHOKE CONTROLS						
	Control, Choke						
	Replace.....		X				
	Control Assembly, Push-Pull						
	Replace.....		X				
04	EXHAUST SYSTEM						
0401	MUFFLER AND PIPES						
	Adapter, Flanged						
	Replace.....		X				
	Muffler, Exhaust						
	Replace.....		X				
	Nipple, Pipe						
	Replace.....		X				
05	COOLING SYSTEM						
0502	COWLING, DEFLECTORS, AIR DUCT, SHROUD						
	Cover, Flywheel						
	Replace.....		X				
	Cover, Shroud						
	Replace.....		X				
	Deflector, Heat						
	Replace.....		X				
	Screen, Flywheel Shroud						
	Service.....	X					

Functional group	Components and related operation	Echelons of maintenance					Remarks
		1	2	3	4	5	
0502	COWLING, DEFLECTORS, AIR DUCT, SHROUD—Continued						
	Replace.....		X				
	Shields, Dust and Air Replace.....		X				
	Shrouds, Flywheel and Cylinder Head Replace.....		X				
06	ELECTRICAL SYSTEM (ENGINE AND VEHICULAR)						
0601	GENERATOR						
	Generator, Engine Accessory, Electrical						
	Service.....	X					
	Test.....		X				
	Replace.....		X				
	Repair.....			X			Install Kit
	Brush Set, Electrical Contact						
	Replace.....		X				
	Belt, "V" Adjust.....	X					
	Replace.....		X				
0602	GENERATOR REGULATOR						
	Regulator, Engine Generator						
	Adjust.....		X				
	Test.....		X				
	Replace.....		X				
0603	STARTER						
	Starter, Engine Electrical						
	Service.....	X					
	Replace.....		X				
	Repair.....			X			Install Kit
	Brush Set, Electrical Contact						
	Replace.....		X				
0604.2	MAGNETO						
	Magneto, Ignition						
	Service.....		X				
	Adjust.....		X				
	Replace.....		X				
	Repair.....			X			Install Kit
	Contact Set, Magneto						
	Replace.....		X				
	Capacitor, Fixed, Paper Dielectric						
	Replace.....		X				
0604.6	IGNITION COIL: WIRING, SPARK PLUGS						
	Cable Assembly, Special Purpose, Electrical						
	Replace.....		X				
	Spark Plug						
	Service.....		X				
	Adjust.....		X				
	Replace.....		X				
0606	ENGINE CONTROLS						
	Switch, Safety, High Temperature						
	Replace.....		X				
	Switch, Cut-Out, Low Oil Pressure						
	Replace.....		X				
	Lead, Electrical						
	Replace.....		X				Fabricate

Functional group	Components and related operation	Echelons of maintenance					Remarks
		1	2	3	4	5	
0607	INSTRUMENT OR ENGINE CONTROL PANEL						
	Ammeter						
	Replace-----		X				
	Lead, Electrical						
	Replace-----		X				Fabricate
0612	BATTERIES						
	Battery, Storage						
	Service-----	X					
	Test-----		X				
	Replace-----		X				
	Cable Assembly						
	Replace-----		X				Fabricate
0615	RADIO SUPPRESSION						
	Capacitor						
	Replace-----		X				
11	REAR AXLE						
1100	REAR AXLE ASSEMBLY						
	Axle Assembly						
	Replace-----			X			
13	WHEELS AND TRACKS						
1311	WHEEL ASSEMBLY						
	Hub Assembly						
	Replace-----		X				
	Repair-----		X				
	Cone and Rollers, Tapered Roller Bearing						
	Service-----		X				
	Replace-----		X				
1813	TIRES, TUBES						
	Tire, Non-Directional and Inner Tube, Pneumatic						
	Service-----	X					
	Replace-----		X				
	Repair-----		X				
15	FRAME						
1501	FRAME ASSEMBLY						
	Base, Cart						
	Replace-----			X			
	Lifting Bail						
	Replace-----		X				
1503	PINTLES AND TOWING ATTACHMENTS						
	Ring, Lunette						
	Replace-----		X				
	Tongue						
	Replace-----		X				
1507	LANDING GEAR; LEVELING JACKS						
	Foot, Cart						
	Replace-----		X				
17	BODY; CAB; HOOD; HULL						
1703	DOORS, HATCHES, HOOD						
	Canopy, Hood						
	Replace-----		X				
	Door, House						
	Replace-----		X				
	Plate, Partition						
	Replace-----		X				
	Rail, Side						
	Replace-----		X				

Functional group	Components and related operation	Echelons of maintenance					Remarks
		1	2	3	4	5	
1704	PANELS						
	Panel, Rear						
	Replace-----			X			
	Cover, Rear Panel						
	Replace-----			X			
	Spacer, Rear Panel						
	Replace-----			X			Fabricate
22	MISCELLANEOUS BODY, CHASSIS OR HULL, AND ACCESSORY ITEMS						
2201.1	MIRRORS, REFLECTORS, PERSONNEL HEATER, DEFROSTERS, WIPERS, AIR HORNS						
	Reflector, Indicator, Clearance						
	Replace-----		X				
2210	DATA PLATES AND INSTRUCTION HOLDERS						
	Plate, Identification						
	Replace-----		X				
	Plate, Identification						
	Replace (C.O.E.)-----			X			
26	ACCESSORIES, PUBLICATIONS, TEST EQUIPMENT AND TOOLS						
2602.1	ACCESSORIES						
	Chock Assembly						
	Replace-----		X				
47	GAGES (NON-ELECTRICAL):						
	WEIGHING AND MEASURING DEVICES						
4701.2	TACHOMETERS						
	Adapter, Straight, Tachometer						
	Replace-----		X				
	Shaft Assembly, Flexible						
	Service-----		X				Lubricate
	Replace-----		X				
	Tachometer and Hourmeter						
	Replace-----		X				
4703.1	OIL PRESSURE GAGES						
	Gage, Pressure, Dial Indicating						
	Replace-----		X				
	Line Assembly, Oil						
	Replace-----		X				Fabricate
4705	FUEL GAGES (QUANTITY)						
	Gage, Fuel						
	Replace-----		X				
55	PUMPS (EXCLUDE ENGINE PUMPS)						
5500	PUMP ASSEMBLY						
	Pump Assembly						
	Service-----	X					
	Inspect-----	X					
	Replace-----		X				
	Repair-----		X				
5501	VOLUTE, HOUSING						
	Chamber, Pump						
	Replace-----		X				
5502	IMPELLER; ROTOR, DIAPHRAGM						
	Impeller						
	Replace-----		X				

Functional group	Components and related operation	Echelons of maintenance					Remarks
		1	2	3	4	5	
5504	DISCHARGE ASSEMBLY Elbow, Street						
	Replace-----		X				
5504.2	SUCTION VALVE, SUCTION HEADS Suction Flange						
	Replace-----		X				
	Suction Head						
	Adjust-----		X				
	Replace-----		X				
5505	LUBRICATORS Cup, Grease						
	Service-----	X					
	Replace-----		X				
5508.2	PUMP DRIVE ASSEMBLY Seal, Bellows Shaft						
	Replace-----		X				
76	FIRE FIGHTING EQUIPMENT						
7603	FIRE EXTINGUISHERS Extinguisher, Fire						
	Replace-----	X					

Page 64. Paragraph 4.

4. Comments and Suggestions (Superseded)

Suggestions and recommendations for changes to the Basic Issue Items List will be submitted on DA Form 2028 to the Commanding Officer, U. S. Army Mobility Support Center, ATTN: SMOMS-MS, P. O. Box 119, Columbus 16, Ohio. Direct communication is authorized.

AGO 7365A

By Order of the Secretary of the Army:

EARLE G. WHEELER,
General, United States Army,
Chief of Staff.

Official:

J. C. LAMBERT,
Major General, United States Army,
The Adjutant General.

Distribution:

Active Army:

DCSLOG (2)
CNGB (1)
CofEngrs (3)
CofT (1)
TSG (1)
USA Maint Bd (1)
USCONARC (3)
AMC (5)
USA Arty CD Agey (2)
USA Armor CD Agcy (2)
USA Inf CD Agcy (2)
USA AD CD Agcy (2)
USA Elct CD Agcy (2)
USA SPWAR CD Agcy (2)
USA Avn CD Agey (2)
OS Maj Comd (5) except
 USASETAF (2) USARJ (10)
MDW (1)
Armies (2)
Corps (2)
Div (2)
Engr Bde (1)
Svc Colleges (2)
Br Svc Sch (2) except USAES (100)
USMA (2)
Gen Dep (OS) (2)
Army Dep (2) except Granite City (10)
 Atlanta, Utah, Memphis, Schnectady (4)
Engr Sec, Gen Dep (10)
Engr Dep (OS) (10)
USA Trans Tml Comd (2)
Army Tml (1)
OSA (2)

Dist Engr (2) except Buffalo, Chicago, Detroit,
Alaska, Los Angeles, New Orleans, New
York, Louisville, Pittsburgh, San Francisco,
Omaha, Seattle, Kansas City, Baltimore,
Ft Worth, Eastern Ocean, Philadelphia,
Rock Island, St Louis, St Paul (1)
Div Engr (2) except Lower Miss Valley, North
Central (none)
Engr Fid Maint Shops (2)
USAERDL (3)
Engr Cen (5)
AMS (3)
Chicago Proc Ofc (10)
USA Mobility Spt Cen (36)
ESCO (10)
Fld Comd, DASA (8)
USAREURCOMZ (2)
USAREUR Engr Proc Cen (2)
USAREUR Engr Sup Con Agcy (10)
MAAG (1)
USA Corps (1)
JBUSMC (1)
Def Logistics Sve Cen (1)
33d Engr Det (FM) (2)
Units org under fol TOE:
 5-48 (2)
 5-237 (5)
 5-262 (5)
 5-267 (1)
 5-278 (5)
 5-279 (2)
 5-500 GI (2)
 55-500 FC, FS (2)

NG: State AG (3)

USAR: Same as Active Army except allowance is one copy to each unit.

For explanation of abbreviations used, see AR 320-50.

Operator and Organizational Maintenance Manual

**PUMP, CENTRIFUGAL: FRESH WATER; GASOLINE DRIVEN:
 2 WHEEL MOUNTED; 4 IN.; 500 GPM, 30 FT HEAD
 (CARVER MODEL K400S) FSN 4320-810-7311
 (LESS ENGINE)**

		Paragraph	Page
CHAPTER	1. INTRODUCTION		
Section	I. General.....	1,2	3
	II. Description and data	3-6	3
CHAPTER	2. INSTALLATION AND OPERATING INSTRUCTIONS		
Section	I. Service upon receipt of equipment.....	7-12	9
	II. Movement to new worksite.....	13, 14	11
	III. Controls and instruments and operation under usual conditions	15-19	11
	IV. Operation under unusual conditions	20-25	16
	V. Operation of materiel used in conjunction with the pumping unit	26, 27	17
CHAPTER	3. OPERATOR AND ORGANIZATIONAL MAINTENANCE INSTRUCTIONS		
Section	I. Lubrication	28,29	19
	II. Preventive maintenance services	30-33	23
	III. Troubleshooting	34-40	29
	IV. Radio interference suppression	41, 42	30
	V. Centrifugal pump and engine removal and installation	43-45	31
	VI. Fuel and exhaust system	46, 47	33
	VII. Electrical system.....	48-53	25
	VIII. Lubrication system.....	54-55	45
	IX. Lunette, tongue, lifting bail, cart foot, reflectors, wheel chocks, crank holddown bracket, and fire extinguisher bracket.....	56-59	45
	X. Wheels, tires, and tubes.....	60,61	48
CHAPTER	4. DEMOLITION OF THE PUMPING UNIT TO PREVENT ENEMY USE	62-66	51
CHAPTER	5. SHIPMENT AND LIMITED STORAGE		
Section	I. Shipment within zone of interior	67,68	53
	II. Limited storage	69,70	53
APPENDIX	I. REFERENCES		55
	II. MAINTENANCE ALLOCATION		57
	III. BASIC ISSUE ITEMS		63
INDEX.....			67

tion II, and Items Troop Installed or Authorized, Section III.

a. *Source, Maintenance, and Recoverability Code(s) (SMR):* Not applicable.

b. *Federal Stock Number.* This column indicates the Federal stock number assigned to the item and will be used for requisitioning purposes.

c. *Description.* This column indicates the Federal item name and any additional description of the item required.

d. *Unit of Measure (U/M).* A 2-character alphabetic abbreviation indicating the amount or quantity of the item upon which the allowances are based, e.g., ft, ea, pr, etc.

e. *Quantity Authorized (Items Troop Installed or Authorized Only).* This column indicates the quantity of the item authorized to be used with the equipment.

Section III. ITEMS TROOP INSTALLED OR AUTHORIZED LIST

(1) SMR code	(2) Federal stock No.	(3) Description Ref. No. & Mfr code	(4) Unit of meas Usable on code	(5) Qty auth
	7520-559-9618	CASE, MAINTENANCE AND OPERATIONAL MANUAL	EA	1
	2990-603-6921	CRANK, HAND	EA	1
	4210-555-8837	EXTINGUISHER, FIRE	EA	1

By Order of the Secretary of the Army:

Official:

VERNE L. BOWERS
Major General, United States Army
The Adjutant General

CREIGHTON W. ABRAMS
General, United States Army
Chief of Staff

Distribution:

To be distributed in accordance with DA Form 12-25A. (qty rqr block No. 242) Organizational maintenance requirements for Pumps, Fresh Water.

CHANGE }
No. 4 }

HEADQUARTERS
DEPARTMENT OF THE ARMY
WASHINGTON, D.C., 28 June 1974

Operator and Organizational Maintenance Manual

**PUMP, CENTRIFUGAL, FRESHWATER; GASOLINE ENGINE DRIVEN;
2-WHEEL MOUNTED; 4-IN, 500 GPM, 30-FT. HEAD
(CARVER MODEL K400S) FSN 4320-810-7311 (LESS ENGINE)**

TM 5-4320-21512, 9 March 1961, is changed as follows:

Safety Precautions Page and Page 11, paragraph 19, add:

WARNING

Operation of this equipment presents a NOISE HAZARD to personnel in the area. The noise level exceeds the allowable limits for unprotected personnel. Wear earmuffs or ear plugs which were fitted by a trained professional.

Safety Precautions Page add:

WARNING

Cleaning solvent, PD-80, is a POTENTIALLY DANGEROUS CHEMICAL. Do not use near open flame.

Page 9, paragraph 11a, add:

By Order of the Secretary of the Army:

Official
VERNE L. BOWERS
*Major General, United States Army
The Adjutant General*

a. Signs conforming to provisions of AR 385-30 will be erected in the operating area to provide notification of noise hazard in accordance with TB MED 251. The signs should read:

WARNING

**NOISE HAZARD EQUIPMENT.
HEARING PROTECTION
REQUIRED.**

Page 19, paragraph 29, add:

WARNING

Dry cleaning solvent, PD-680, used for cleaning is a POTENTIALLY DANEROUS CHEMICAL. Do not use near open flame. Flash point of solvent is 100F 138F.

Distribution:

To be distributed in accordance with DA Form Ia-25A (qty rqr block No. 242) organizational maintenance requirements for Pumps, Fresh Water.

CREIGHTON W. ABRAMS
*General, United States Army
Chief of Staff*

Change }
No.3 }

HEADQUARTERS
DEPARTMENT OF THE ARMY
Washington, D.C., 29 June 1973

**Operator and Organizational Maintenance Manual
PUMP, CENTRIFUGAL, FRESH WATER; GASOLINE
DRIVEN; 2 WHEEL MOUNTED; 4 IN; 500 GPM; 30 FT. HEAD (CARVER
MODEL K400S) FSN 4320-810-7311 (LESS ENGINE)**

TM 54320-215-12, 9 March 1961, is changed as follows:

Page 3. Subparagraph 1d is superseded as follows:

d. You can improve this manual by calling attention to errors and by recommending improvements, using DA Form 2028 (Recommended Changes to

Publications), or by letter, and mailing directly to Commander, U.S. Army Troop Support Command, ATTN: AMSTS-MPB, 4300 Goodfellow Blvd., St. Louis, Mo. 63120.

Page 63. Appendix III is superseded as follows:

**APPENDIX III
BASIC ISSUE ITEM LIST AND ITEMS
TROOP INSTALLED OR AUTHORIZED**

Section I. INTRODUCTION

1. Scope

This appendix lists basic issue items, items troop installed or authorized which accompany the pump and are required by the crew/operator for operation, installation, or operator's maintenance.

2. General

This basic issue items, items troop installed or authorized list is divided into the following sections:

a. *Basic Issue Items List-Section II.* Not applicable.

b. *Items Troop Installed or Authorized List-Section III.* A list in alphabetical sequence of items which, at the discretion of the unit commander, may accompany the end item, but are NOT subject to be turned in with the end item.

3. Explanation of Columns

The following provides an explanation of columns in the tabular list of Basic Issue Items List, Sec-

*This change supersedes C2, 4 November 1969.

CHAPTER 1 INTRODUCTION

Section I. GENERAL

1. Scope

a. These instructions are published for the use of personnel to whom the Carver Centrifugal Pump, Model K400S, is issued. They contain information on the operation and organizational maintenance of the equipment. This manual also provides a description of the main units and their functions in relationship to other components.

b. Appendix I contains a list of publications applicable to this manual. Appendix II contains the maintenance allocation chart and appendix III contains the basic issue items authorized for use of the operator of this equipment. The organizational maintenance repair parts and special tool lists are in TM 5-4320-215-20P.

c. The numbers placed in parentheses on illustrations within this manual indicate quantity.

d. Report all deficiencies as specified in AR 700-38. Submit recommendations for changes, additions, or deletions to The Commanding General, U.S. Army Engineer Maintenance Center, Corps of Engineers, ATTN: EMCDM, P. O. Box 119, Columbus 16, Ohio. Direct communication is authorized.

2. Operator and Organizational Maintenance Record and Report Forms

For record and report forms, applicable to the first and second echelons of maintenance, refer to TM 5-505.

Section I. DESCRIPTION AND DATA

3. Description

a. *General.* The Carver Centrifugal Pump (figs. 1 and 2), Model K400S, is a self-contained, wheel-mounted, fresh water pump. It consists of a gasoline engine (fig. 1) and a centrifugal-type pump (fig. 2). The engine of the pumping unit is completely enclosed and is equipped with doors for easy access to all components. The unit is equipped with two 12-v (volt), 100-amp (amperes) batteries and box (fig. 1), a battery-charging generator and the necessary controls and instruments. A lifting bail (fig. 1) is provided for lifting the pumping unit.

b. *Pump.* The pump (fig. 2) is a self-priming, pedestal-mounted, centrifugal-type unit designed for pumping fresh water. The pump is directly coupled to the engine (fig. 1).

4. Identification

This pumping unit has one identification and instruction plate. The data on this plate can be found in paragraph 6.

5. Differences in Models

This manual covers only the Carver Model K400S Pumping Unit. No known unit differences exist for the model covered by this manual.

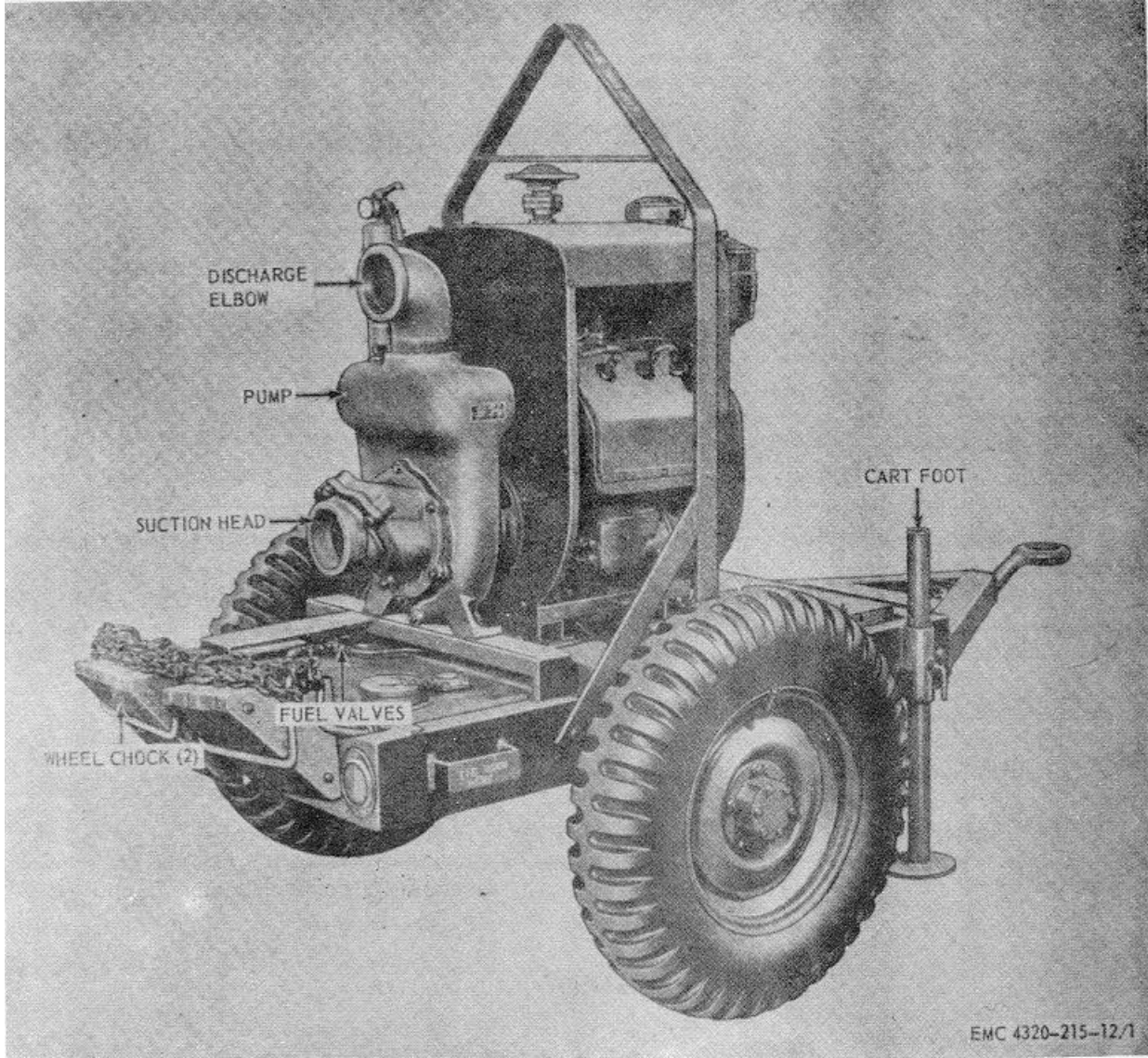

Figure 1. Centrifugal pump, right rear, three-quarter view.

6. Tabulated Data

a. General.

ManufacturerCarver Pump Company
 Model.....K400S
 TypePortable, gasoline-driven
 MountWheel-mounted

b. Engine.

ManufacturerWisconsin Corporation
 Model.....MVF4D
 Motor

Number of cylinders.....4
 TypeAir cooled
 Rated horsepower.....18.2 net continuous
 Compression ratio.....5.8 to 1

c. Pump.

ManufacturerCarver Pump Company
 Model.....K400S
 TypeCentrifugal
 Maximum capacity.....703 gpm (gallons per minute)
 Rated capacity5600 gpm

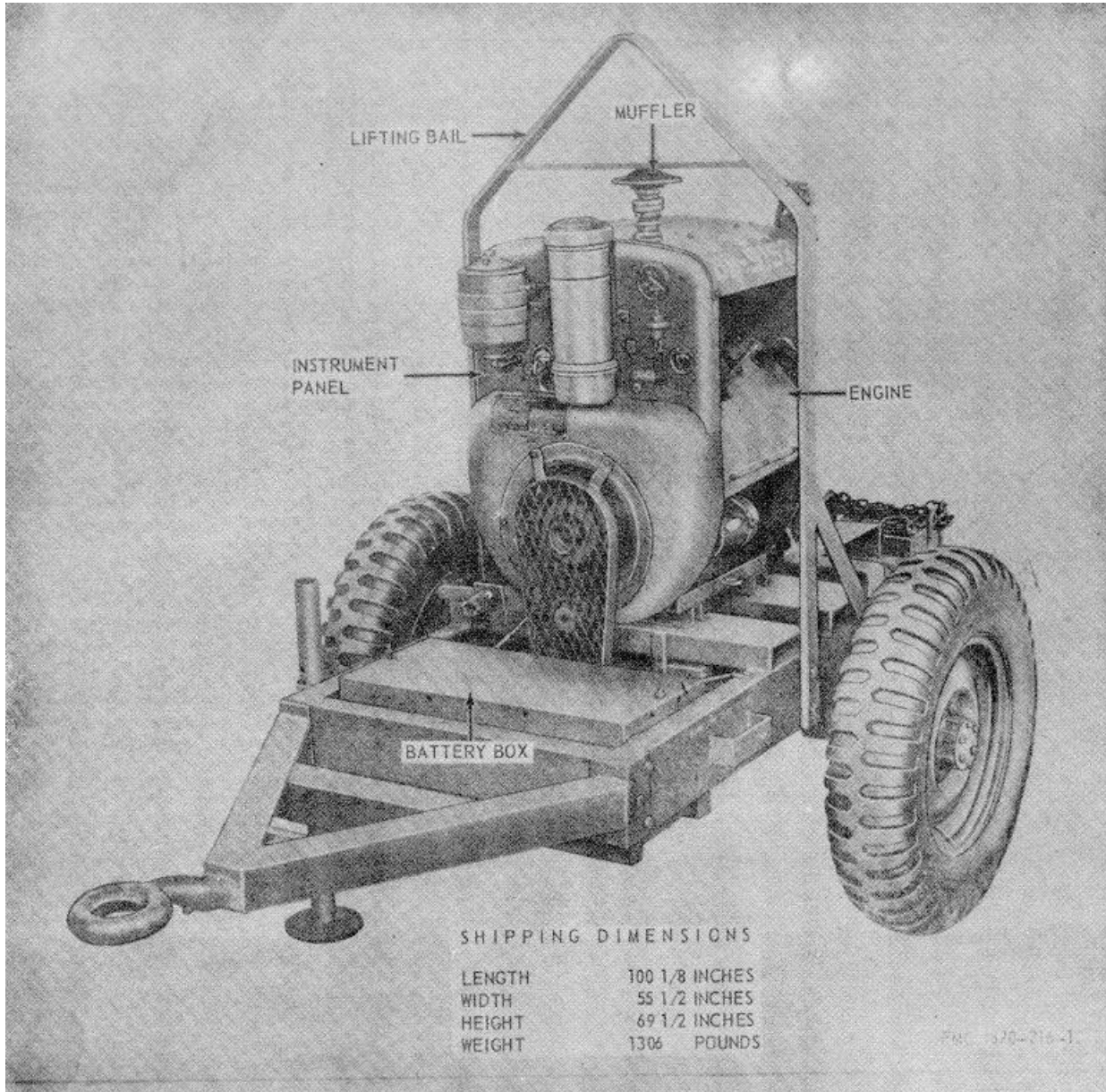

Figure 1. Centrifugal pump, left front, three-quarter view, with shipping dimensions.

d. Corps of Engineers Plate.

ManufacturerCarver Pump Company
 Model.....K400S
 Stock number4320-810-7811
 Length100 1/8 in. (inches)
 Width55 1/2 in.
 Height.....69 1/2 in.
 Shipping weight1.806 lb (pounds)

e. Voltage Regulator.

ManufacturerElectric Auto-Lite
 Corporation
 Model.....V.B.O.-4402-AT
 Voltage24 v
 Ground polarityNegative

f. Maintenance and Operating Supplies. Table I provides a list of all oils, greases, and

Table 1. Maintenance and Operating Supplies

Item	Component application	Source of supply	Federal stock No.	Description	Quantity required for initial operation	Quantity required for 8 hours operation	Notes
1.	0101 CRANK-CASE (1)			OIL, LUBRICATING: 5 gal drums, as follows:			(1) Includes quantity of oil to fill engine oil system as follows: 4 qt—Crankcase 1 qt—Oil Filter 3/8 qt—Air Cleaner (2) See SM 10-1-C4-1 for additional data and requisitioning procedure. (3) See LO 5-4320-215-12 for grade application and replenishment intervals.
		10	9150-265-9435(2)	OE-30	5-3/8 qt	(3)	
		10	9150-265-9428(2)	OE-10	5-3/8 qt	(3)	
	0106.2 OIL FILTER (4)			OIL, LUBRICATING (4)			(4) Use oil as prescribed in item 1 above. (5) Tank capacity. (6) Average fuel consumption is 2.87 gal per hr of continuous operation.
3.	0304 AIR CLEANER (4)			OIL, LUBRICATING (4)			
4.	0306 FUEL TANK	10	9130-160-1818(2)	GASOLINE: AUTOMOTIVE, BULK	12 gal (5)	22.96 (6)	
5.	5505 LUBRICATORS	10	9150-190-0904(2)	GREASE, AUTOMOTIVE AND ARTILLERY. 1 lb CAN	as rqr	as rqr(3)	

fuels required for the initial operation of the pumping unit.

Crankcase.....4 qt (quarts)
Oil filter.....1 qt
Air cleaner8/8 qt

g. Dimensions and Weight.

Length100 1/8 in.
Width.....55 1/2 in.
Height.....69 1/2 in.
Weight.....1,06 lb

i. Tires.

Size7.00-16
Pressure46 psi (pounds per square inch)

h. Capacities.

Fuel tank.....12 gal (gallons)

j. Wiring Diagram. Refer to figure 8 for the practical wiring diagram for the electrical system.

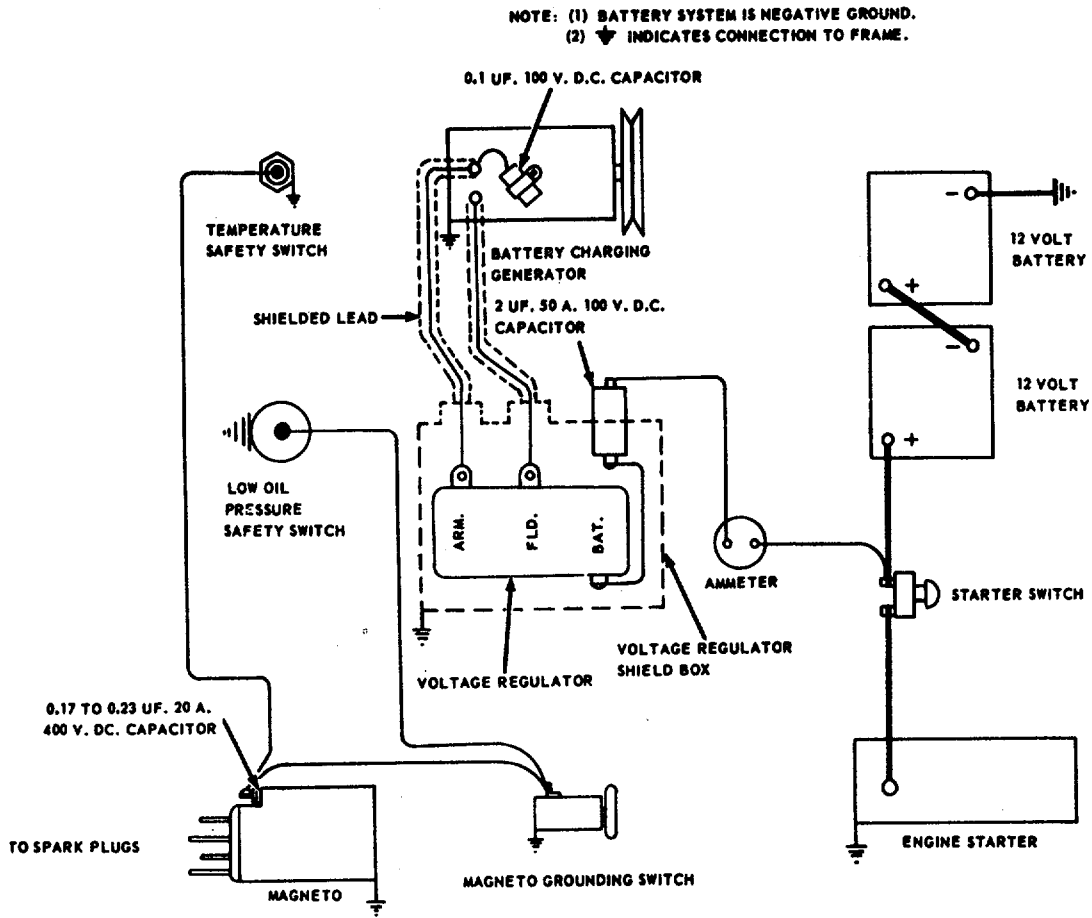

EMC 4320-215-12/3

Figure 3. Practical wiring diagram.

**CHAPTER 2
INSTALLATION AND OPERATING INSTRUCTIONS**

Section I. SERVICE UPON RECEIPT OF EQUIPMENT

7. Unloading of Equipment

- a. Remove all tiedown straps and blocks that secure the pumping unit to the bed of the carrier.
- b. Remove the pumping unit from the bed of the carrier with a crane or by towing. If a crane is used, attach the cables of the crane to the lifting bail (fig. 1).

Warning

When lifting the pumping unit from the bed of the carrier, be sure that the lifting device has a capacity of at least 2,000 pounds. Do not allow the pumping unit to swing while suspended. Failure to observe this warning may result in damage to the unit or severe injury to personnel.

8. Unpacking New Equipment

- a. Position the pumping unit as near the worksite as possible. Remove any protective material that may be on the unit.
- b. Cut the binding straps that secure the electrolyte to the pumping unit. Do not uncrate the electrolyte until it is to be used.

9. Inspection of New and Used Equipment

- a. Inspect all equipment received against the packing list. Examine the identification plate for positive identification of the equipment.
- b. Inspect the pumping unit for damaged or missing parts. Pay particular attention to used equipment.
- c. Refer to paragraph 31 for a guide to inspection of the pumping unit.

10. Installation of Separately Packed Components

- a. Refer to paragraph 12 and install the batteries.
- b. Remove the caps from the batteries and fill each cell with electrolyte. Be sure that the plates are covered with three-eighths inch of electrolyte.
- c. Refer to TM 9-6140-200-15 for detailed information on storage batteries.

Warning

Do not smoke or use an open flame when servicing the batteries. Batteries generate hydrogen, a highly explosive gas.

11. Installation or Setting-up Instructions

- a. *General.* The pumping unit may be installed indoors or outdoors, with temporary or permanent mounting. Locate the unit as near as possible to the source of supply.
- b. *Leveling.* The pumping unit should be as level as possible. When necessary, the pumping unit will operate up to 150 off level. A leveling cart foot (fig. 2) is provided for help in leveling the unit. Wheel chocks (fig. 2) are used instead of brakes.
- c. *Indoor Installation.* Make sure that the floor of the enclosure is of sufficient strength to support the weight of the unit. Install a flexible exhaust hose to carry exhaust gases to the outside. Use as few bends as possible and see that all connections are tight.

Warning

When the unit is operated in an inclosed area, exhaust gases must be piped to the outside. Continued breathing of exhaust gases is dangerous and may be fatal.

d. *Outdoor Installation.* Avoid muddy, sandy, or wet locations if possible. If it is necessary to install the unit on soft ground, provide planking or logs for a foundation.

e. *Suction and Discharge Lines.* The suction and discharge line diameters should never be less than the diameter of their respective pump connections. They should possibly be one or two sizes larger, based on friction loss incurred, due to pipe and fittings in the lines. The suction and discharge lines should not depend upon the pump for support. They should be independently supported to avoid pump misalignment and distortion.

f. *Auxiliary Fuel Supply.* If the pumping unit is to be operated for extended periods of time, an auxiliary fuel supply should be connected to the auxiliary fuel valve (fig. 2).

a. *Servicing.* Refer to paragraph 31 and perform the operator's daily services.

b. *Lubrication.* Lubricate as described in the current lubrication order.

c. *Fuel System.* Refer to table I and fill the fuel tank with the proper grade of fuel.

d. *Batteries.*

(1) Refer to paragraph 10 and fill the batteries with electrolyte.

(2) Remove and install the batteries and connect the cables as shown by figure 4.

12. Servicing Now and Used Equipment

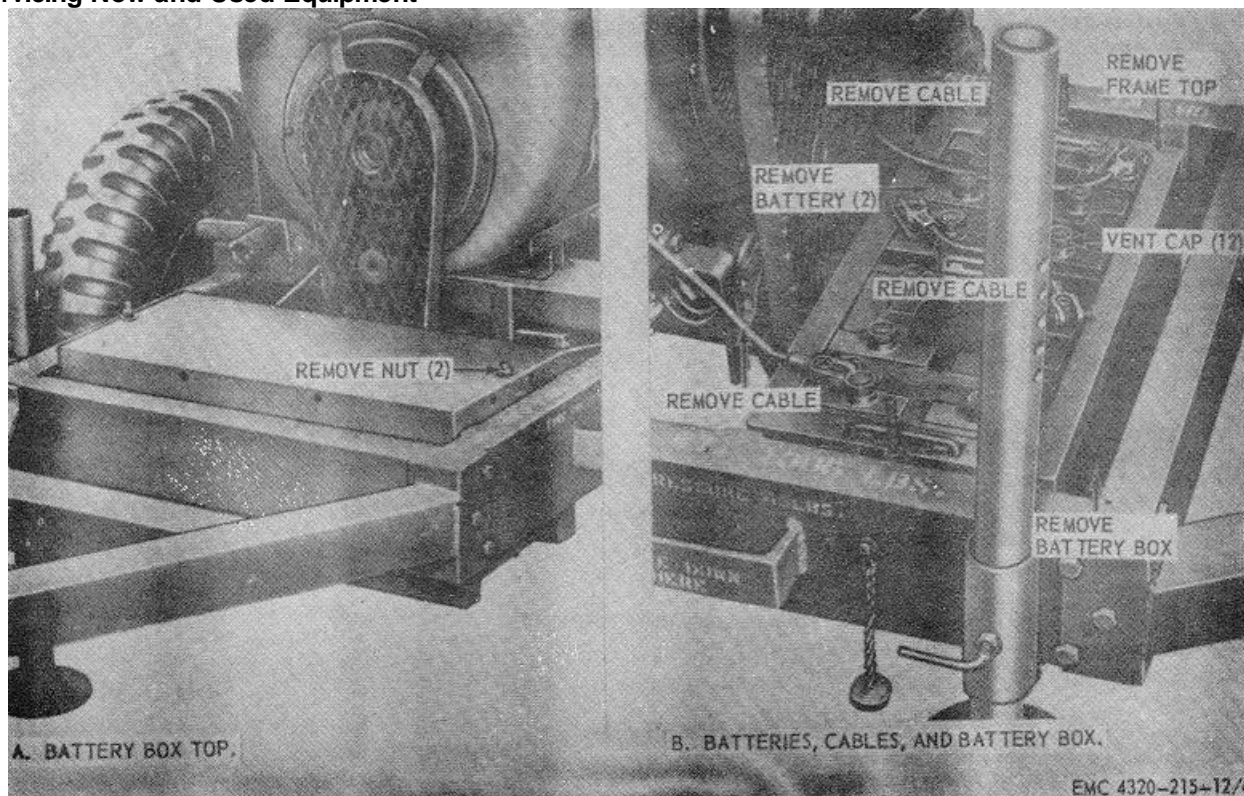

Figure 4. Batteries, cables, and battery box, removal and installation.

Section II. MOVEMENT TO NEW WORKSITE

13. Dismantling for Movement

- a. Disconnect the auxiliary fuel line, if used, from the auxiliary fuel valve (par. 11).
- b. Disconnect the exhaust pipe extension if used.
- c. Disconnect the suction and discharge lines.
- d. Disconnect the ground line. (See TM 5-2805-209-12.)

- e. Clean and stow all tools and equipment.
- f. Install all doors and panels and tow the pumping unit to the new worksite.

14. Reinstallation After Movement to a New Worksite

Refer to paragraph 11 for reinstallation after movement to a new worksite.

Section III. CONTROLS AND INSTRUMENTS AND OPERATION UNDER USUAL CONDITIONS

15. Controls and Instruments

Refer to TM, 5280--209-12 for purpose and normal readings of the engine controls and instruments. For the purpose and normal readings of the pumping unit controls and instruments, refer to figure 5.

16. Operation Under Usual Conditions

It is essential that the operator know how to perform every operation of which the pumping unit is capable.. Since nearly every job presents a different problem, the operator may have to vary the given procedures to fit the individual job. Refer to paragraphs 17, 18, and 19 for starting, stopping, and operating details.

17. Engine Starting Instructions

- a. Perform the before-operation services listed in paragraph 81.
- b. Remove the two doors from the engine before operating.

- c. In the event that the pumping unit is new or the chamber has been drained, it will be necessary to prime the pump as shown by figure 6.

- d. Start the engine as shown by figure 7.

18. Engine Stopping Instructions

Stop the engine as shown by figure 8.

19. Operating Details

- a. *Normal Operations.*

- (1) Start the engine (par. 17).
- (2) Perform the during-operation services (par. 31).
- (3) Refer to figure 5 and observe instruments for normal operation.

- b. *Emergency Operation.* Refer to TM 5-2805-209-12 for field expedient repairs of the engine.

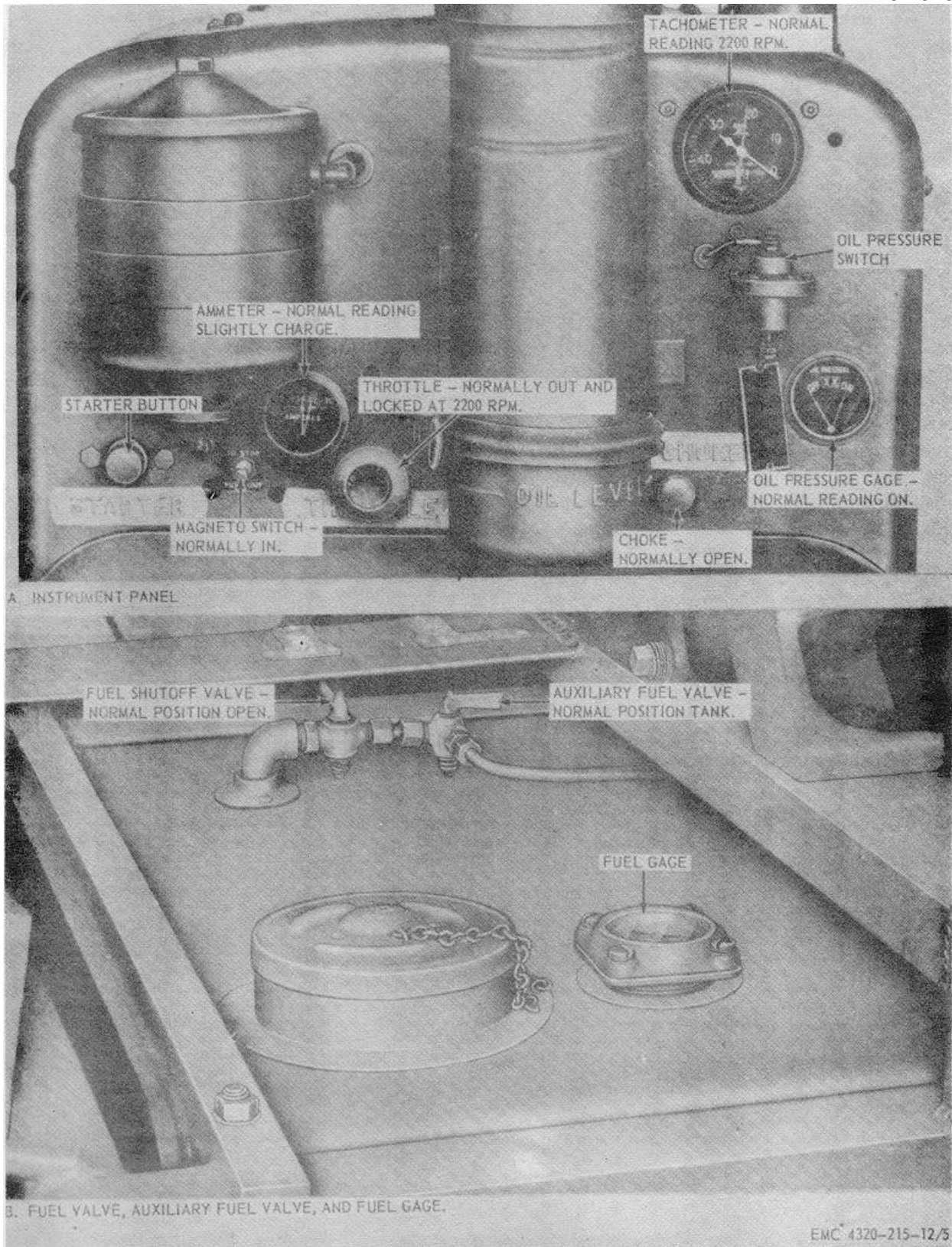

Figure 5. Controls and instruments.

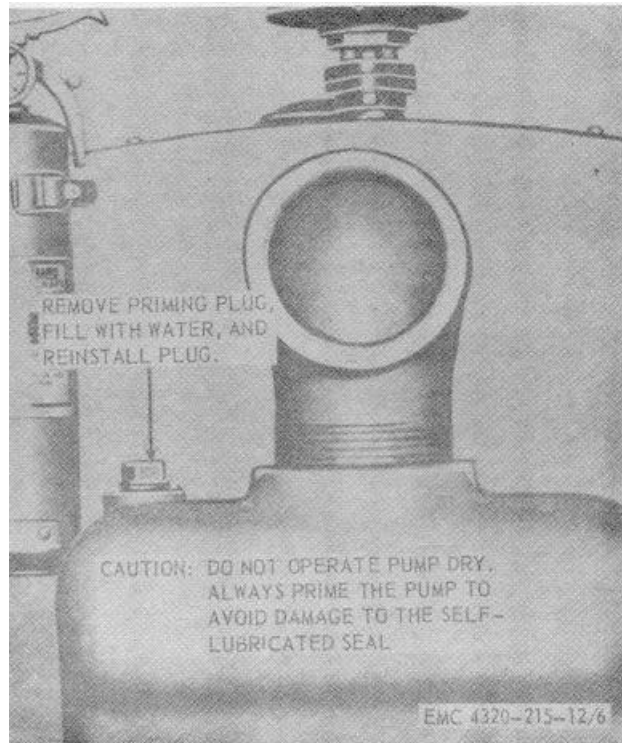

Figure 6. Pump priming instructions.

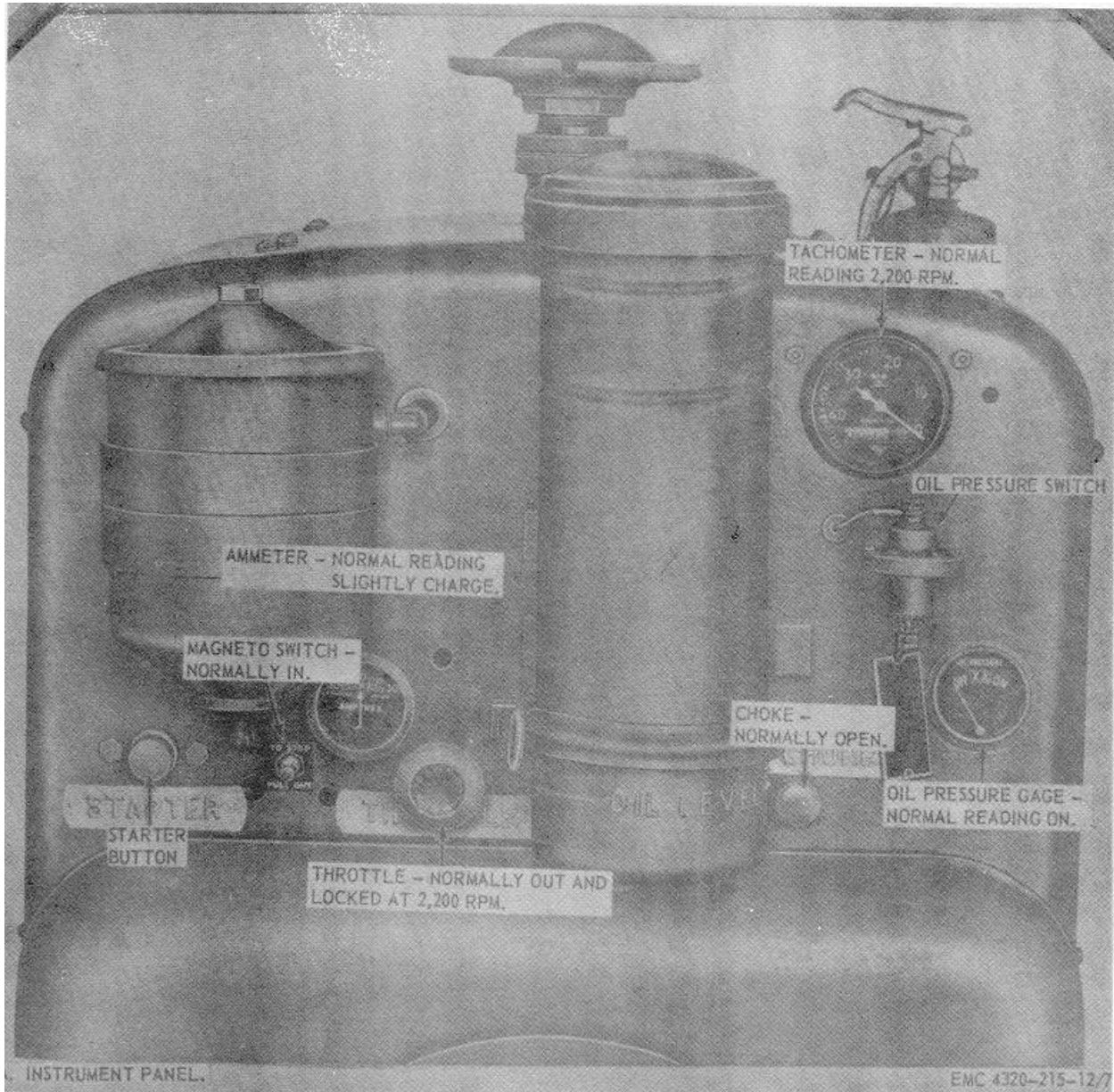

Figure 7. Engine starting instructions.

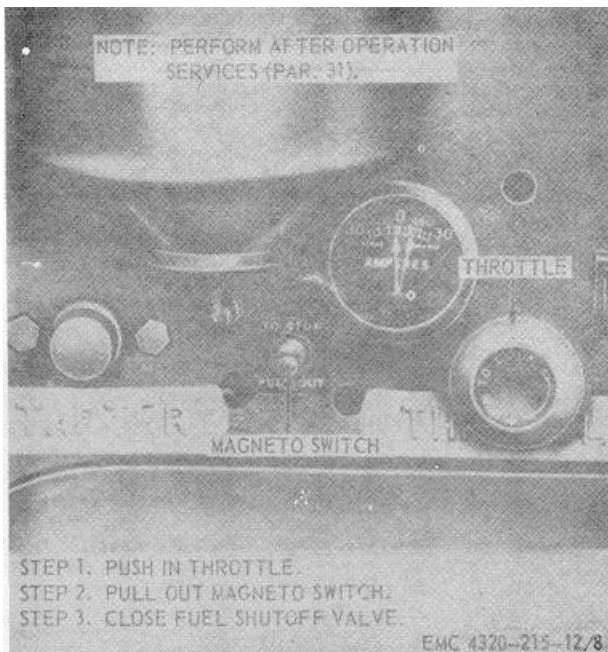

Figure 8. Engine stopping instructions.

Section IV. OPERATION UNDER UNUSUAL CONDITIONS

20. Operation in Extreme Cold (Below 0° F.)

a. General. Operation of the pumping unit in extreme cold requires special precautions and extra servicing if proper operation is to be achieved.

b. Fuel System. Keep the fuel tank full at all times. Service the fuel pump sediment bowl and fuel strainer daily (TM 5-2805-209-12).

c. Lubrication. Lubricate the pumping unit in accordance with the current lubrication order.

d. Electrical System. Before starting the engine, wipe the engine electrical system components free of ice and moisture. Do not disturb electrical wiring since it becomes brittle with extreme cold. Allow the wiring to warm up before attempting to bend it. To lessen the possibility of damage to the batteries and to increase efficiency, be sure that the batteries are fully charged.

Caution

Run the engine for approximately 1 hour after adding water to the batteries. This will permit added water to mix with the electrolyte and prevent freezing.

e. Pump. When operating the unit in a temperature below 0° F., the use of warm water in priming the pump will thaw ice films on the impeller and seal the prevent damage. Do not use hot water in extremely cold weather because this may result in cracking the chamber. When not in use, drain the pump. If water is allowed to stand in the pump, freezing may burst the chamber.

21. Operation in Extreme Heat

a. General. Operation of the pumping unit under extremely high temperatures requires special servicing and precautions. If the unit is to be operated indoors, make sure the ventilation is adequate.

b. Fuel System. Do not fill the fuel tank too full. Allow sufficient room for fuel expansion.

c. Lubrication. Lubricate the pumping unit in accordance with the current lubrication order.

22. Operation in Dusty or Sandy Areas

a. General. If the installation of the pumping unit is permanent, erect a protective shelter for the unit. In temporary installations take advantage of natural barriers as much as possible. Keep the unit as clean as possible.

b. Lubrication. In dusty or sandy areas, the oil filter and air cleaner must be serviced more frequently than under normal conditions. For service of the oil filter and air cleaner, refer to TM 5-280-209-12. Be sure that the lubricant containers are tightly sealed and stored in an area as free as possible from dust and sand.

c. Fuel System. Take the necessary precautions to keep dirt and grit from entering the fuel system. Clean the fuel strainer each time the fuel supply is replenished (TM 5-2805209-12).

23. Operation Under Rainy or Humid Conditions

When the pumping unit is operated outdoors, erect a shelter, if possible, to protect-the unit. If the erection of a shelter is not possible, keep the pumping unit covered with a canvas or other waterproof device when inoperative. Remove the cover during dry periods and allow the unit to dry out. Keep the fuel tank full to prevent forming of condensation.

24. Operation in Salt Water Areas

a. General. Salt water causes a corrosive action on metal. Care must be taken to avoid contact of equipment with salt water. If the unit is exposed to salt water, wash the unit frequently with fresh water.

b. Painting. Paint all exposed metal surfaces Refer to TM 9-2851. Coat all exposed polished surfaces with standard-issue, rustproofing material, if available, or cover with a light coat of grease

25. Operation at High Altitudes

The pumping unit is designed to operate at elevations up to 5,000 feet above sea level without special service or adjustment. For maximum

operational efficiency above 5,000 feet, it may be necessary to readjust the carburetor. Refer to TM 5-

2805-209-12 for proper carburetor adjustment at altitudes above 5,000 feet.

Section V. OPERATION OF MATERIEL USED IN CONJUNCTION WITH THE PUMPING UNIT

26. Fire Extinguisher (Bromochloromethane Type)

a. Description. A bromochloromethane fire extinguisher (fig. 10) is provided with the equipment. It is a vaporizing, liquid-type, pressurized, trigger-operated pump of 1 quart capacity.

b. Operation. Remove the fire extinguisher from its location and squeeze trigger. Direct the stream at the base of the flame.

- (2) Break the seal by pulling the safety pin from the handle.
- (3) Point the horn at the base of the flame.
- (4) Depress the trigger for discharge and direct the stream of contents at the base of the fire.
- (5) Replace with a new cylinder immediately after using.

Warning

Be extremely careful when using a bromochloromethane fire extinguisher in an inclosed area. A poisonous gas is generated by the contact of bromochloromethane with a heated metallic surface. Provide adequate ventilation before entering an inclosed area where bromochloromethane has been used.

c. Refilling and Maintenance. For refilling and maintenance, refer to field maintenance.

27. Fire Extinguisher (Monobromotrifluoromethane Type)

a. Description. The monobromotrifluoromethane type fire extinguisher replaces the carbon dioxide and carbon tetrachloride type fire extinguishers and in the past. It is generally suitable for all types of fire, with the exception of fires involved with LOX (liquid oxygen) generating equipment. The fire extinguisher is furnished with a disposable-type cylinder.

b. Operation. To operate the fire extinguisher, perform the following operations:

- (1) Remove the fire extinguisher from its location.

c. Replacement of Cylinder. To replace with a new cylinder, perform the following operations:

- (1) Press the lever to release pressure from the old cylinder.
- (2) Loosen the swivel valve coupling nut and remove the valve assembly from the used cylinder.
- (3) Remove the instruction band from the used cylinder.
- (4) Place the new cylinder through the instruction band.
- (5) Replace the safety pin in the valve and seal with sealing wire.
- (6) Attach the valve assembly and tighten the swivel coupling nut on the new cylinder and replace the fire extinguisher in the mounting bracket.
- (7) Adjust the instruction band on the cylinder to show maintenance and operating instructions.

d. Maintenance. Weigh the fire extinguisher every 6 months and replace the cylinder if the gross weight has decreased 4 ounces or more. Lubricate the cylinder neck threads with 1 drop of OE 30 oil before reassembly.

CHAPTER 3
OPERATOR AND ORGANIZATIONAL MAINTENANCE INSTRUCTIONS

Note

No special tools or equipment are needed by the operator or organizational maintenance personnel for maintenance of this pumping unit.

Section I. LUBRICATION

28. General Lubrication Information

a. This section contains a reproduction of the lubrication order and lubrication instructions which are supplemental to, and are not specifically covered in the lubrication order.

b. The lubrication order shown in figure 9 is an exact reproduction of the approved lubrication order for the pumping unit. For the current lubrication order, refer to DA Pam 810-4.

c. For engine lubrication, refer to TM 5-2805-209-12.

29. Detailed Lubrication Information

a. *Care of Lubricants.* Keep all lubricants (grease and oil) in closed containers and store in a clean, dry place away from external heat. Allow no dirt, dust, water, or other foreign material of any kind to mix with

the lubricants. Keep all lubrication equipment clean and ready for use.

b. *Points of Lubrication.* Refer to figure 9 for illustration of the lubrication points.

c. *Cleaning.* Keep all external parts, not requiring lubrication, clean of lubricants. Before lubricating the equipment, wipe all lubrication points free of dirt and grease. Clean all lubrication points after lubricating to prevent accumulation of foreign matter.

d. *Oil Filter.* For service of the oil filter, refer to TM 52805-209-12.

e. *Air Cleaner.* For service of the air cleaner, refer to TM 5-2805-209-12.

f. *Wheel Bearing.* For service of the wheel bearing, refer to paragraph 61.

**LUBRICATION
ORDER**

LO 5-4320-215-12

**PUMP, CENTRIFUGAL: FRESH WATER; GASOLINE DRIVEN;
2 WHEEL MOUNTED; 4 IN.; 500 GPM; 30 FT HEAD
(CARVER MODEL K400S) W/WISCONSIN
ENGINE MODEL MVF4D**

Reference: SM 10-1-C4-1

Intervals are based on normal operations. Reduce to compensate for abnormal operation and severe conditions. During inactive periods sufficient lubrication must be performed for adequate preservation.

Relubricate after washing.

Clean fittings before lubricating.

Clean parts with SOLVENT, dry-cleaning, or with OIL, fuel, Diesel. Dry before lubricating.

Lubricate points indicated by dotted arrow shafts on both sides of the equipment.

Drain crankcase only when hot after operation; replenish and check level when cool.

LUBRICANT • INTERVAL

INTERVAL • LUBRICANT

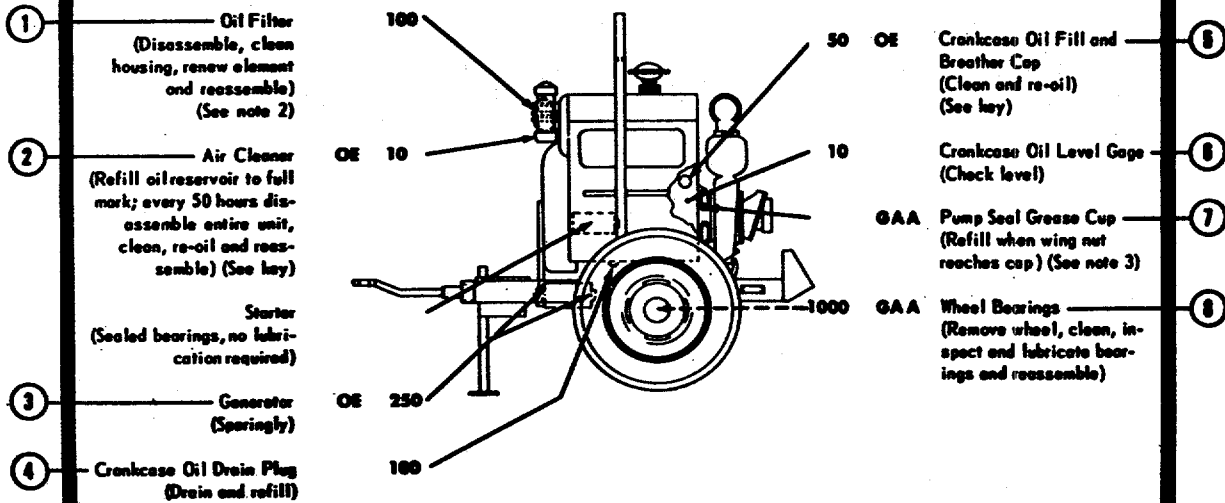

CONTINUED ON FOLLOWING PAGE

ENC 4320-215-12/9 ①

Figure 9. Lubrication order.

CONTINUED FROM
PRECEDING PAGE
- KEY -

LUBRICANTS	CAPACITY	EXPECTED TEMPERATURES			INTERVALS
		Above +32°F	+40°F to -10°F	0°F to -65°F	
OE - OIL, Engine, Heavy Duty		OE 30 or 9250	OE 10 or 9110	OES	Intervals given are in hours of normal operation.
Crankcase	5 qt				
Air Cleaner	3/8 qt				
Oil Can Points					
OES - OIL, Engine, Subzero		All Temperatures			
GAA - GREASE, Automotive and Artillery					

NOTES:

1. FOR OPERATION OF EQUIPMENT IN PROTRACTED COLD TEMPERATURES BELOW -10°F. Remove lubricants prescribed in the key for temperatures above -10°F. Clean parts with SOLVENT, dry-cleaning. Relubricate with lubricants specified in the key for temperatures below -10°F.
2. OIL FILTER. After installing new filter element, fill crankcase, operate engine 5 minutes, check housing for leaks, check crankcase oil level and bring to full mark.
3. PUMP SEAL GREASE CUP. To fill cup turn wing nut clockwise to cap, remove cap, fill cup, replace cap and turn wing nut counterclockwise to top of shaft.
4. OIL CAN POINTS. Every 50 hours clean and lightly coat throttle linkage, leveling jacks and door latches with OE.

Copy of this Lubrication Order will remain with the equipment at all times; instructions contained herein are mandatory.

BY ORDER OF
SECRETARY OF THE ARMY:

G. H. DECKER,
General, United States Army,
Chief of Staff.

OFFICIAL:
R. V. LEE,
Major General, United States Army,
The Adjutant General.

ENC 4320-215-12/9 ②

Figure 9. Continued

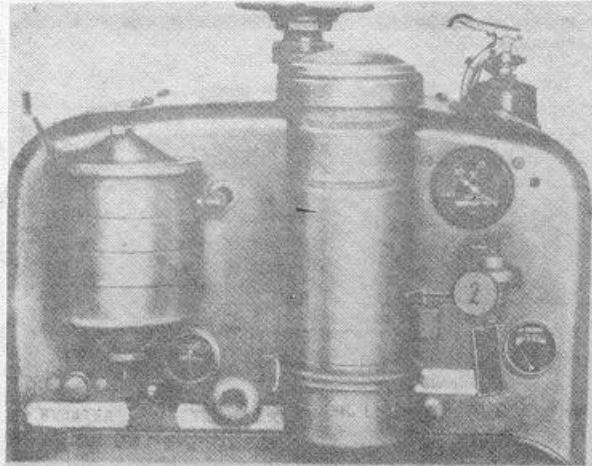

REF. 1 - OIL FILTER
REF. 2 - AIR CLEANER

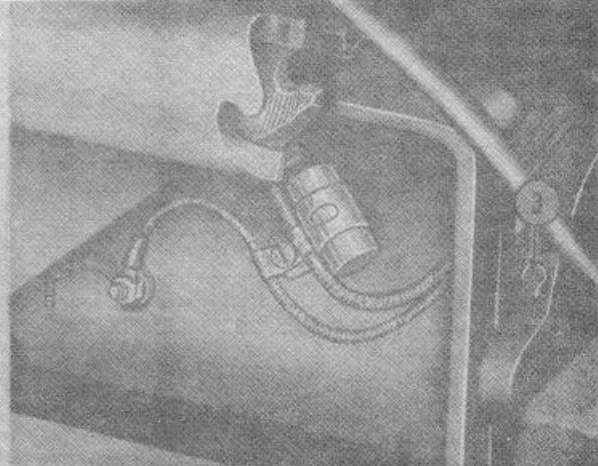

REF. 3 - GENERATOR

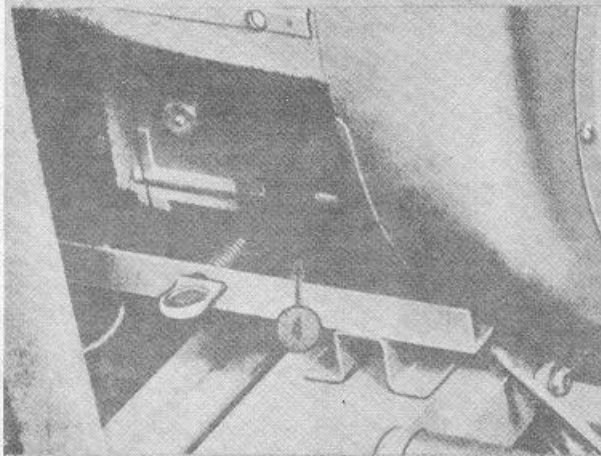

REF. 4 - CRANKCASE OIL DRAIN PLUG

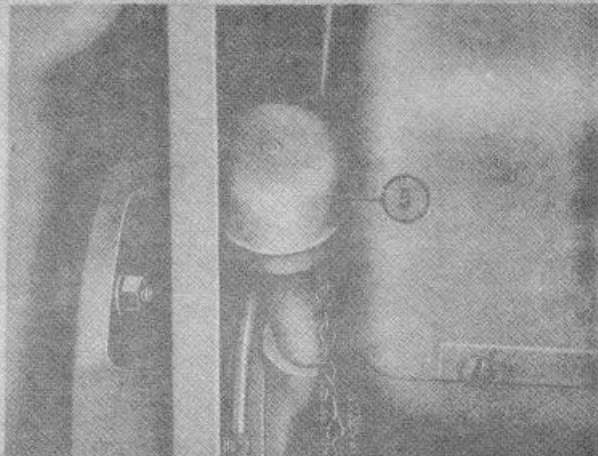

REF. 5 - CRANKCASE OIL FILL AND BREATHER CAP

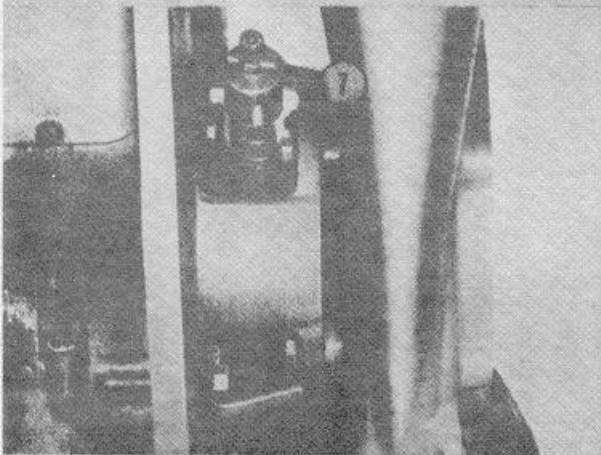

REF. 6 - CRANKCASE OIL LEVEL GAGE
REF. 7 - PUMP SEAL GREASE CUP

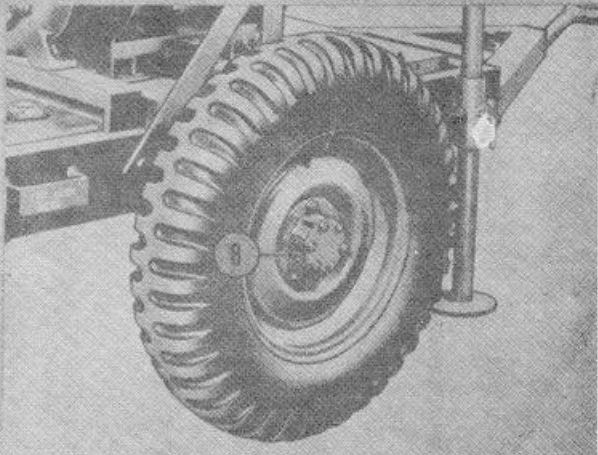

REF. 8 - WHEEL BEARING

EMC 4320-215-12/9

Figure 9. Continued

Section II. PREVENTIVE MAINTENANCE SERVICES

30. General

To insure that the equipment is ready for operation at all times, it must be inspected systematically before operation, during operation, and after operation, so that defects may be discovered and corrected before they result in serious damage or failure. The necessary preventive maintenance services will be performed before operation. Defects discovered during operation of the unit will be noted for future correction to be made as soon as operation has ceased. Stop operations immediately if a deficiency is noticed during operation which would damage the equipment if operation were continued. After-operation services will be performed at intervals based on the normal operations of the unit. Reduce intervals to Compensate for abnormal conditions. Defects or unsatisfactory operating characteristics beyond the scope of the operator to correct must be reported at the earliest possible opportunity to organizational maintenance. Responsibility for performance of preventive maintenance services rests not only with the operator, but with the entire chain of command from section chief to commanding officer (AR 750-5).

31. Operator's Daily Services

a. *General.* The intervals at which the operator's daily services are to be performed are indicated by an x in the appropriate column, on the small tab, located at the bottom of each illustration in figure 10. The tab columns are B (before), D (during), and A (after) operation of the equipment. The intervals and services not illustrated are prescribed in the following subparagraphs.

b. *Before-Operation Services.*

- (1) *Visual Inspection.* Visually inspect the entire pumping unit for damaged or missing parts or insecure mounting. Correct all discrepancies or report them to organizational maintenance.
- (2) *Publications.* Make sure that a copy of this manual, TM 5-2805-215-12, the current lubrication order, and DA Form 285, are on or with the unit and in serviceable condition.

(3) *Lubrication.* Lubricate the pumping unit in accordance with the current lubrication order. For lubrication of the engine, refer to TM 5-2805-20912.

(4) *Leaks, general.* Inspect the entire pumping unit for evidence of fuel or oil leaks. Correct all deficiencies or report them to organizational maintenance.

c. *During-Operation Services.*

(1) *Visual inspection and observation.* Visually inspect the pumping unit for loose mountings. Observe the pumping unit, while in operation, for excessive vibration, unusual noises, overheating, and smoking. If any of the above discrepancies are noted, shut down the pumping unit. Correct or report the discrepancies to organizational maintenance.

(2) *Leaks, general.* Inspect the pumping unit for fuel or oil leaks. Inspect the suction and discharge lines for leaks. Correct or report all leaks to organizational maintenance.

d. *After-Operation Services.*

(1) *Lubrication.* Lubricate the pumping unit in accordance with the current lubrication order.

(2) *Cleaning.* Clean all dirt and grease from the pumping unit.

(3) *Protection.* See that all doors and covers are installed on the pumping unit. If outdoors, cover with a suitable waterproof cover.

32. Organizational Maintenance

a. Preventive maintenance is performed by organizational maintenance at quarterly intervals. The quarterly interval is equivalent to 3 calendar months or 250 hours of operation, whichever occurs first.

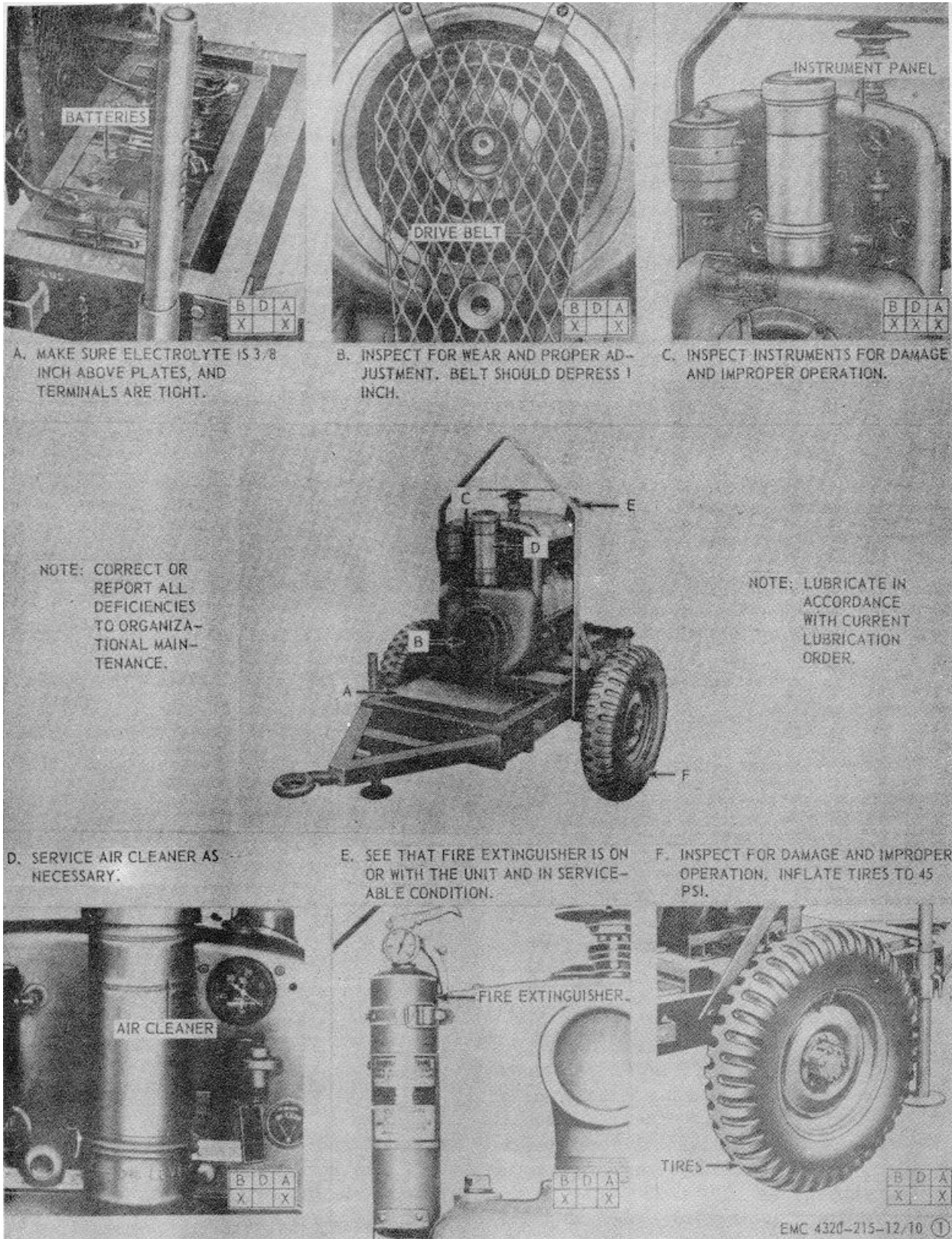

A. MAKE SURE ELECTROLYTE IS 3/8 INCH ABOVE PLATES, AND TERMINALS ARE TIGHT.

B. INSPECT FOR WEAR AND PROPER ADJUSTMENT. BELT SHOULD DEPRESS 1 INCH.

C. INSPECT INSTRUMENTS FOR DAMAGE AND IMPROPER OPERATION.

D. SERVICE AIR CLEANER AS NECESSARY.

E. SEE THAT FIRE EXTINGUISHER IS ON OR WITH THE UNIT AND IN SERVICEABLE CONDITION.

F. INSPECT FOR DAMAGE AND IMPROPER OPERATION. INFLATE TIRES TO 45 PSI.

Figure 10. Operator's daily services.

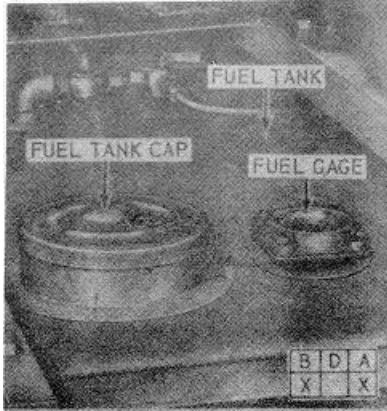

G. INSPECT FOR DAMAGE AND LEAKS. FILL FUEL TANK AS NECESSARY.

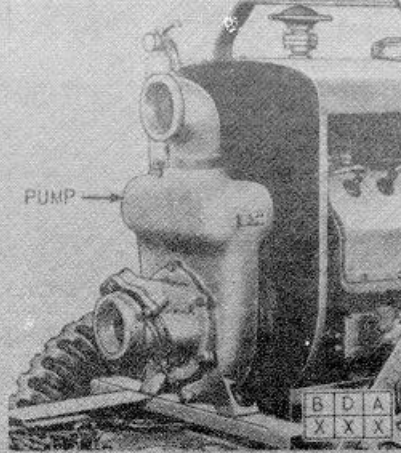

H. INSPECT FOR LEAKS AND CRACKED CHAMBER.

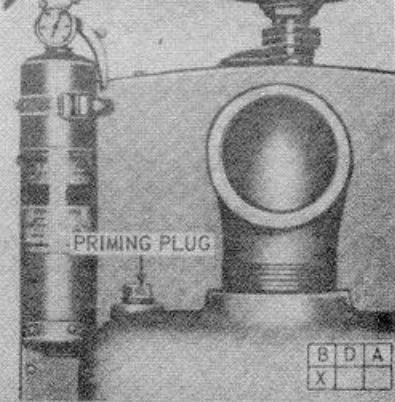

I. REMOVE PLUG AND SEE THAT PUMP IS PRIMED.

NOTE: CORRECT OR REPORT ALL DISCREPANCIES TO FIELD MAINTENANCE.

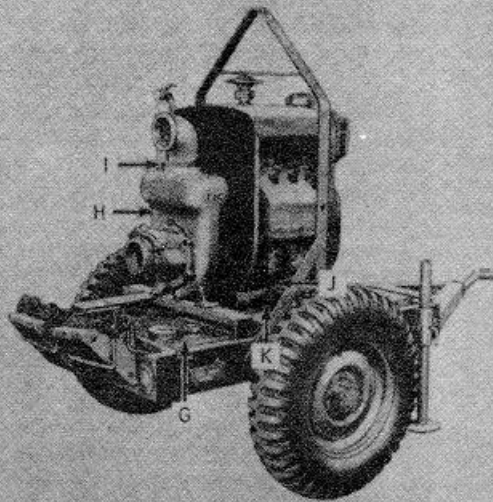

NOTE: LUBRICATE IN ACCORDANCE WITH CURRENT LUBRICATION ORDER.

J. CHECK OIL LEVEL. ADD OIL AS NECESSARY.

K. INSPECT BOWL FOR SEDIMENT AND LEAKS.

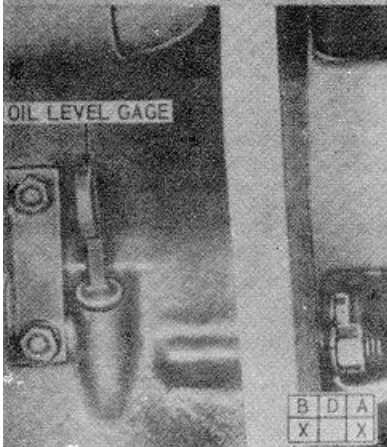

Figure 10. Continued

b. The preventive maintenance services to be performed at quarterly intervals are listed and described in paragraph 33. The number opposite each service refers to a corresponding number on DA Form 464 and

indicates the services to be performed. The number listed under "inspection" indicates the minimum inspection requirements for the equipment.

33. Quarterly Preventive Maintenance Service

Inspection	Service Quarterly	GENERAL
1	1	<i>Before-operation services.</i> Perform the before operation services listed in paragraph 31.
2	2	<i>Lubrication.</i> Inspect the entire pumping unit for damaged oil lines, leaking oil seals, and indications of insufficient lubrication.
	2	Lubricate in accordance with the current lubrication order. Replace damaged lines or fitting. Correct or report all deficiencies to field maintenance.
3	3	<i>Tools and equipment.</i> Inspect the condition of all tools and equipment assigned to the unit.
	3	Make sure they are clean and properly stowed or mounted.
4	4	<i>Fire extinguisher.</i> Inspect the bromochloromethane type fire extinguisher for insufficient charge, judging by sound and weight. Do not discharge contents.- Inspect for excessive corrosion and insecure mounting.
	4	Correct all deficiencies or report them to field maintenance. Refer to field maintenance for refilling and maintenance. Weigh a monobromotribfluoromethane type fire extinguisher every six months and replace the cylinder if the gross weight has decreased four ounces or 'on Lubricate the cylinder neck threads with one drop of OE 30 oil before reassembly.
5	5	<i>Publications.</i> See that a copy of this manual, TM 5-280 -20912, the current lubrication order, and DA Form 285 are on or with the equipment and in serviceable condition.
6	6	<i>Appearance.</i> Inspect the general appearance of the pumping unit, paying special attention to uncleanliness, illegibility of identification markings, and poor condition of paint.
	6	See that all deficiencies noted are corrected' or reported to field tenance.
7	7	<i>Modifications.</i> See that all available modification work orders applying to this pump unit have been complied with and recorded on DA Form 478, DA Form 5-73, and DA Form 5-73a, as applicable.
		ENGINE
11	11	<i>Cylinder head, manifolds, mufflers, and exhaust pipe.</i> Inspect the intake and exhaust manifolds for crack, breaks, lose mounting, and evidence of leakage. Inspect the muffler and exhaust pipe for loose mounting, leaks, and excessive rust.
	11	Tighten all mounting hardware. Replace a defective intake or exhaust manifold, gaskets, muffler, and exhaust pipe (TM 5-280209-12)
12	12	<i>Valve mechanism.</i> Inspect the valve cover and gasket for signs of damage. Inspect the valve mechanism for defective part. Make r that the valve mechanism is receiving sufficient lubrication.
	12	Replace a defective valve cover or gasket (TM 5-2805-209-12). Report defective valves or insufficient lubrication to field maintenance.
13	13	<i>Compression test.</i> Refer to TM 5-2805-2o09-12 and test the compression of each cylinder.

Inspection	Service Quarterly	ENGINE-Continued
	13	If the compression tests show poor compression, report the condition to field maintenance.
14	14	<i>Engine breather.</i> Inspect the engine breather for damage and clogging.
	14	Clean a dirty or clogged breather or replace a defective breather (TM 5-2805-209-12).
15	15	<i>Oil filter.</i> Inspect the oil filter for loose mounting, dirt, and leaks. Inspect the oil lines for leaks and deterioration.
	15	Tighten all loose connections and mounting hardware. Refer to TM 5-2805-209-12 and service the oil filter. Replace a damaged oil filter (TM 5-2805-209-12).
17	17	<i>Fan and shroud.</i> Inspect the fan and shroud for insecure mounting, leaks, or misalignment.
	17	Refer to TM 6-2805-209-12 and replace a damaged fan. Tighten all loose mounting hardware.
18	18	<i>Belts and pulleys.</i> Inspect the belt for cracks, breaks, fraying, and improper adjustment. Inspect the pulleys for cracks, chips, and coring.
	18	Adjust or replace the belt as necessary (par. 49). Report a defective pulley to field maintenance.
20	20	<i>Governor and linkage.</i> Inspect the governor and linkage for cracks, breaks, loose mounting, and improper operation. Inspect the governor for evidence of leakage.
	20	Refer to TM 6-2805-209-12 and correct all deficiencies noted.
22	22	<i>Primer.</i> Inspect the primer for improper operation, loose mounting, and leakage.
	22	Refer to TM 5-2805-209-12 and correct all deficiencies noted.
38	38	<i>Fuel pump.</i> Inspect the fuel pump for cracks, breaks, loose mounting, and leaks.
	38	Refer to TM 5-2805-209-12 and correct all deficiencies noted.
39	39	<i>Carburetor and throttle control rod.</i> Inspect the carburetor and control rod for cracks, breaks, and improper adjustment. Inspect the carburetor for evidence of leakage. Inspect the control rod for improper operation.
	39	Refer to TM 5-2801-209-12 and correct all deficiencies noted.
40	40	<i>Fuel strainer.</i> Inspect the fuel strainer for cracks, breaks, leaks, and other damage.
	40	Refer to TM 5-2805-209-12 and correct all deficiencies noted.
41	41	<i>Air cleaner.</i> Inspect the air cleaner for insecure mounting, defective hose, and clogged filter element.
	41	Refer to TM 5-2805-209-12 and correct all deficiencies noted.
43	43	<i>Fuel tank, cap, and strainer.</i> Inspect the fuel tank for leaks. Inspect the fuel tank cap for a defective gasket and insecure mounting. Inspect the fuel strainer for hole.
	43	Tighten or replace loose or missing mounting hardware. Replace a fuel tank cap or gasket as necessary. Replace a defective fuel strainer. Replace a defective fuel tank (par. 47).
44	44	<i>Fuel lines.</i> Inspect the fuel line for cracks, breaks, kinks, and leakage.
	44	Tighten all loose connections. Replace all defective fuel lines (par. 47).
46	46	<i>Spark plugs and leads.</i> Inspect the spark plugs for cracked porcelain, burned electrodes, carbon deposits, and incorrect gap. The correct gap is 0.025 inch. Use a suitable spark plug tester and test each spark plug for improper operation. Inspect spark plug leads for damage and loose or corroded connections.

Inspection	Service Quarterly	ENGINE-Continued
47	46 47	Refer to TM 6-2805-209-12 and correct all deficiencies noted. <i>Batteries, box, and cables.</i> Inspect the electrolyte for improper level. The electrolyte should be three-eighths inch above the plates Test the specific gravity and record it on DA Form 464. Inspect the batteries for cracks and excessive corrosion. Inspect the battery cables for loose connections, fraying, and corrosion. Inspect the battery box for dents, insecure mounting, and corrosion.
48	47 48 48	Clean all corrosion from the batteries, box, and cables. Replenish the electrolyte as necessary (par. 10). Replace defective batteries (par. 12). Replace a defective battery box and cables (par. 58). Tighten all loose connections. <i>Generator and starter.</i> Inspect the generator and starter for loose mounting hardware and electrical connections. Inspect for excessive dirt and grease. Tighten all loose mounting hardware and electrical connection. Remove all dirt and grease. Replace a defective generator (par. 650). Refer to TM 5-2805-209-12 and replace a defective starter.
49	49	<i>Magneto.</i> Inspect the magneto for cracks, breaks, and loose mounting. Inspect the spark plug lead connections for looseness and corrosion. Remove the end cap cover and inspect the distributor block for cracks, breaks, dirt, and worn terminals. Inspect the point get for wear, deposits, and improper adjustment.
50	49 50	Refer to TM 5-2805-209-12 and correct all deficiencies noted. <i>Wiring and switches.</i> Inspect all wiring for broken or frayed insulation and loose or broken connection Inspect all switches for insecure mounting, loose or corroded terminals and connections, and faulty operation.
51	50 51	Refer to TM 6-2805-20-12 and correct all deficiencies noted. <i>Voltage regulator.</i> Inspect the voltage regulator for insecure mounting, loose electrical connections, and improper operation. Tighten all loose mounting hardware and electrical connections Adjust or replace a defective voltage regulator as necessary (par. 51).
52	52 52	<i>Reflectors.</i> Inspect the reflectors for loose or missing mounting hardware and broken glass. Tighten all loose mounting hardware. Replace a defective reflector (par. 58).
57	57 57	<i>Gages.</i> Inspect all gages for cracked or broken glass. Inspect for insecure mounting and loose connections. Inspect the gage for improper operation. Tighten all loose mounting hardware and connections. Refer to TM 5-2805209-12 and correct all deficiencies noted.
58	58 58	<i>Meters.</i> Inspect all meters for cracked or broken glass and insecure mounting. Inspect all meters for improper operation. Tighten all loose mounting hardware. Warning: Disconnect the batteries when servicing electrical instruments, except when current is necessary for testing. Replace a defective ammeter (par. 52). Refer to TM 5-28062-12 for replacement of all other meters.
59	59 59	<i>Valves.</i> Inspect the suction valve and gasket for cracks, breaks, and deterioration. Inspect for improper operation. Replace a defective suction valve (par. 44).

Inspection	Service Quarterly	ENGINE-Continued
76	76	<i>Tires.</i> Inspect tires for breaks, deterioration, and improper tire pressure.
	76	Repair or replace a defective tire (par. 61). Inflate tires to proper tire pressure. Correct tire pressure is 45 psi.
77	77	<i>Lunette.</i> Inspect the lunette for loose or missing mounting hardware.
	77	Tighten or replace all loose or missing mounting hardware. Replace a defective lunette (par. 58).
78	78	<i>Wheels.</i> Inspect the wheels for insecure mounting hardware and improper lubrication.
	78	Tighten all loose mounting hardware. Replace a defective wheel (par. 61).
80	80	<i>Frame.</i> Inspect for misalignment, loose or missing hardware, cracked or broken welds, and other signs of damage. Inspect the lifting bail for damage.
	80	Tighten or replace all loose or missing mounting hardware. Replace a defective lifting bail (par. 58). Report a defective frame to field maintenance.
84	84	<i>Hood, panels, and doors.</i> Inspect for dents, cracks, breaks, or other damage. Inspect for loose or missing mounting hardware.
	84	Tighten or replace all loose or missing mounting hardware. Refer to TM 5-2805-209-12 and correct all deficiencies noted.
CENTRIFUGAL PUMP		
136	136	<i>Cart foot.</i> Inspect the cart foot for insecure mounting, misalignment, or other evidence of damage. Inspect the pin and securing handle for damage or improper operation.
	136	Replace a defective cart foot (par. 57).
183	183	<i>Impeller.</i> Inspect the impeller for insecure mounting, cracks, breaks, and improper clearance.
	188	Tighten a loose mounting. Adjust the clearance between the suction head and impeller (par. 44). Replace a defective impeller (par. 44).
184	184	<i>Oil seal.</i> Inspect the mechanical seal for evidence of leakage (par. 44). Inspect the suction flange and suction head for defective gaskets.
	184	Replace a defective mechanical seal (par. 44). Replace a defective suction flange or suction head gasket.
185	185	<i>Pump housing.</i> Inspect chamber for cracks, breaks, misalignment, and loose or missing mounting hardware.
	185	Tighten or replace all loose or missing mounting hardware. Replace a defective chamber (par. 44).

Section III. TROUBLESHOOTING

34. General

This section provides information useful in diagnosing and correcting unsatisfactory operation or failure of the pumping unit and its components. Each trouble symptom stated is followed by a list of probable causes of the trouble. The possible remedy recommended is described opposite the probable cause. Any operational trouble that is beyond the scope of

organizational maintenance must be reported to field maintenance, 3d echelon.

35. Engine Troubleshooting

For engine troubleshooting, refer to TM 5-2805-209-12.

36. Pump Fails To Prime

<i>Probable cause</i>	<i>Possible remedy</i>
Priming hole plugged	Clean the chamber interior.
Air leak in suction line	Tighten the hose connections. Inspect the hose for collapsed line.
Defective seal	Replace the seal (par. 44).
Impeller clogged, broken, or worm.	Clean or replace the impeller (par. 44).

37. Pump Fails To Deliver

<i>Probable cause</i>	<i>Possible remedy</i>
Pump not properly Primed	Prime the pump (par. 17).
Speed too low	Check the engine speed. Readjust the governor if necessary. Refer to TM 5-2805-209-12.
Total head too high	Rearrange the pumping system to reduce the distance between the water supply and the point of discharge.

38. Pump Fails To Produce Rated Capacity

<i>Probable cause</i>	<i>Possible remedy</i>
Air leak in suction line	Tighten the connections.
Speed too low	Check the engine speed. Readjust the governor if necessary. Refer to TM 5-2805-209-12.
Suction lift too high	Move the pump closer to water supply.
Impeller partially clogged ..	Clean the impeller.

39. Pump Pressure Insufficient

<i>Probable cause</i>	<i>Possible remedy</i>
Speed too slow	Check the engine speed. Readjust the governor if necessary. Refer to TM 5-2805-209-12.

Air in the line	Completely submerge suction line.
Excessive clearance between impeller and suction head	Remove the suction head gaskets to produce a proper clearance of 0.005 to 0.010 inch.

40. Field Expedient Repairs

Operational troubles may occur while the pumping unit is operating in the field, where supplies and repair parts are not available and normal remedial action cannot be performed. When this condition exists, the expedient remedies listed below may be used only upon the decision of the unit commander. Equipment so repaired must be removed from operation at the earliest possible moment and properly repaired before being placed in operation again.

<i>Trouble</i>	<i>Expedient remedy</i>
Air cleaner clogged	Remove the air cleaner (TM 5-2806-209-12).

Caution

Operating the unit in sandy or dusty areas without the air cleaner can cause serious damage to the engine.

Fuel strainer clogged	Remove the element (TM 5-2805-209-12).
Temperature safety switch defective.	Disconnect the electrical wire from the oil pressure switch and tape the ends (TM5-2805-209-12).

Caution

Do not operate the pumping unit longer than necessary without the temperature safety switch. Should a low oil pressure condition develop, serious damage to the engine may result.

Section IV. RADIO INTERFERENCE SUPPRESSION

41. General Methods Used To Attain Proper Suppression

Essentially, suppression is attained by providing a low-resistance path to ground for stray currents. The methods used to attain suppression include shielding the ignition and high-frequency wires, grounding the frame with bonding straps, and using capacitors and resistors where necessary. For general information on radio interference suppression, refer to TM 11-483.

42. Interference Suppression Components

- a. Refer to figure 11 for the location, removal, and installation of radio interference suppression components.
- b. To correct faulty radio interference suppression, remove the suppression components and substitute with new ones until the defective component is found.
- c. Always replace suppression components with identical parts.

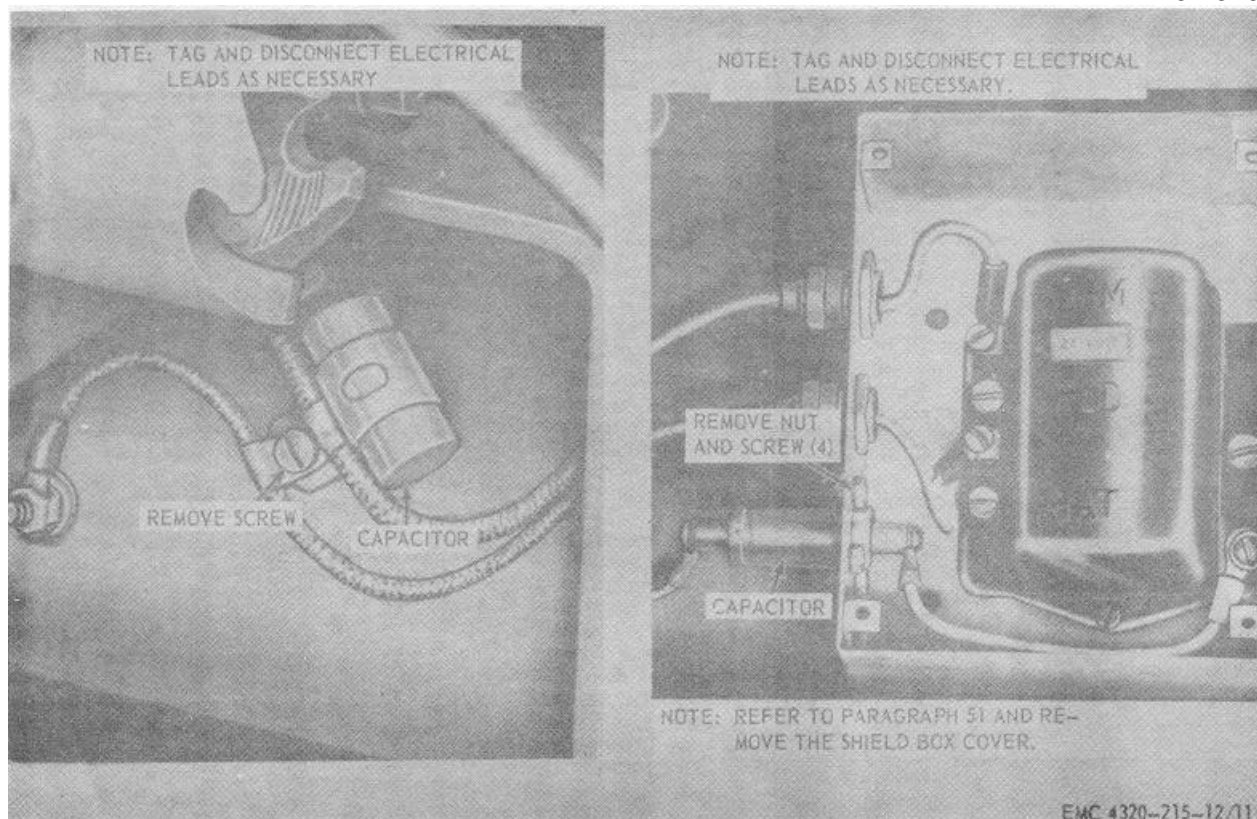

Figure 11. Radio interference suppression components, location, removal, and installation.

Section V. CENTRIFUGAL PUMP AND ENGINE REMOVAL AND INSTALLATION

43. General

This section includes instructions for the removal and installation of the centrifugal pump, engine, and the centrifugal pump components.

44. Centrifugal Pump, Grease Cup, Reducer, and Nipple

- a. Remove the fuel tank and fuel line (par. 47).
- b. Remove and install the centrifugal pump, grease cup, reducer, and nipple as shown by figure 12.
- c. Clean, inspect, and repair.
- d. Adjust the impeller as shown by figure 13.

45. Engine

- a. Remove and install the centrifugal pump (par. 44).
- b. Remove and install the belt guard and generator drive belt (par. 49).
- c. Remove and install the battery cables (par. 12).
- d. Remove and install the fuel tank (par. 47).
- e. Remove and install the ammeter lead (par. 52).
- f. Remove and install the lifting bail (par. 58).
- g. Remove and install the engine as shown by figure 14.

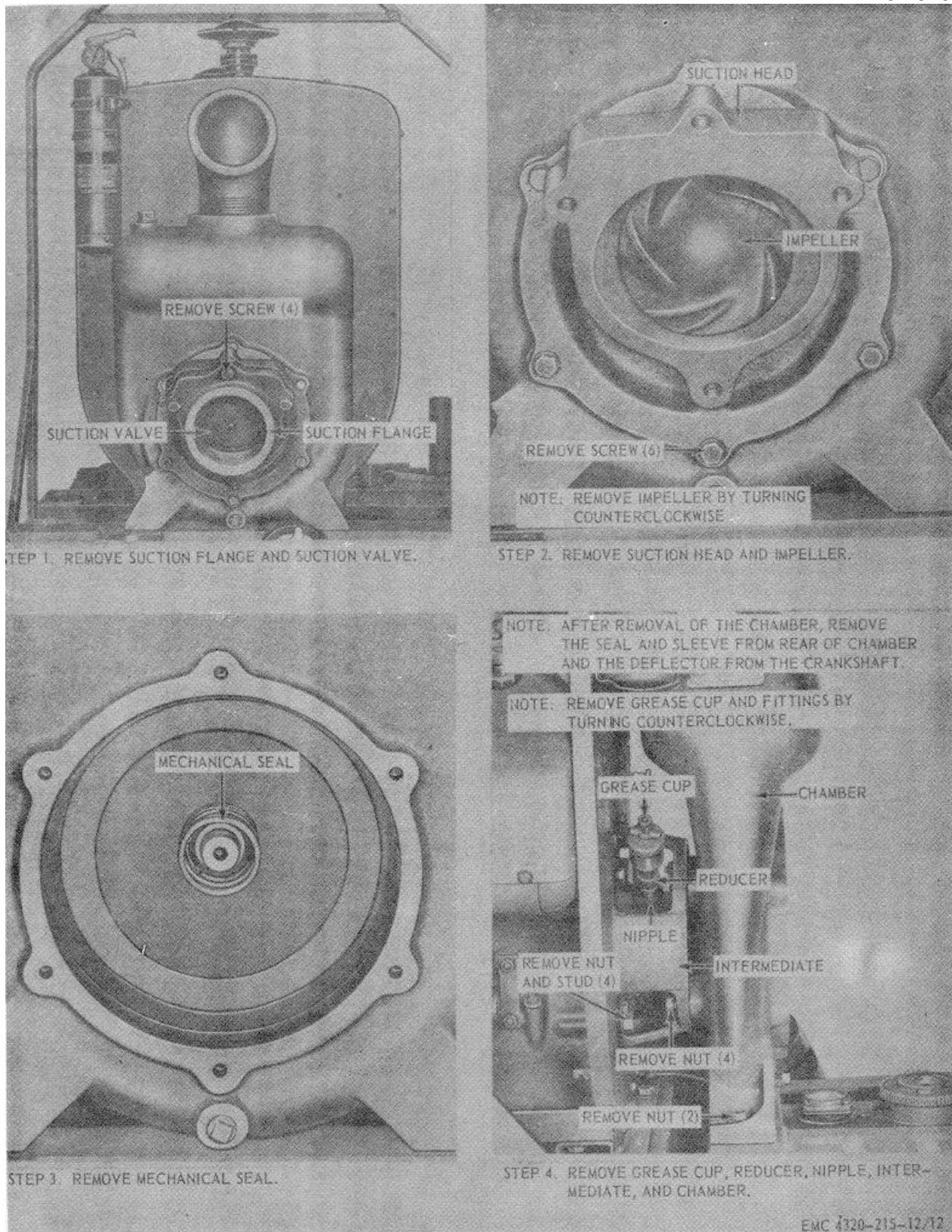

Figure 12. Centrifugal pump, grease cup, reducer, and nipple, removal and installation.

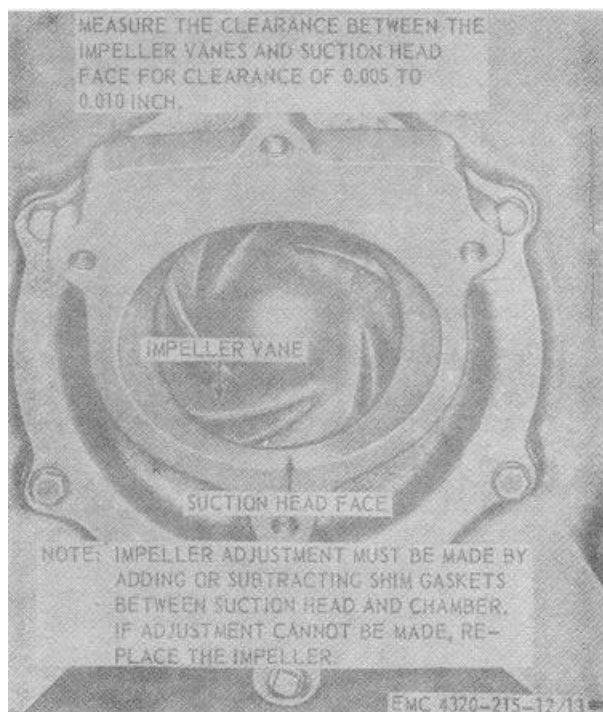

Figure 13. Impeller clearance adjustment.

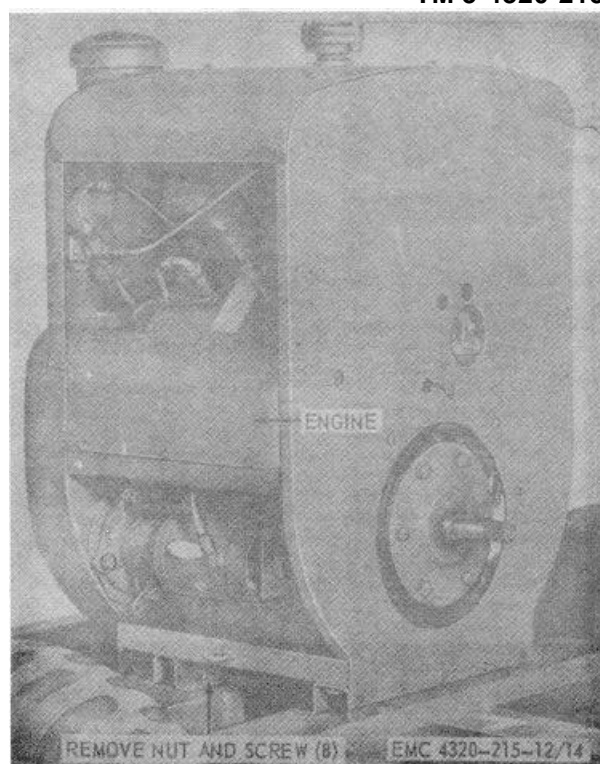

Figure 14. Engine, removal and installation.

Section VI. FUEL AND EXHAUST SYSTEMS

46. General

This section includes maintenance instructions on the fuel and exhaust system components that are not described in TM 5-2805-209-12. For operator and organizational maintenance on the fuel and exhaust systems, refer to TM 52805-209-12.

47. Fuel Tank and Fuel Line

- a. Remove and install the fuel tank and fuel line as shown by figure 15.
- b. Clean and inspect.
- c. Disassemble and reassemble the fuel tank as shown by figure 16.
- d. Clean and inspect.

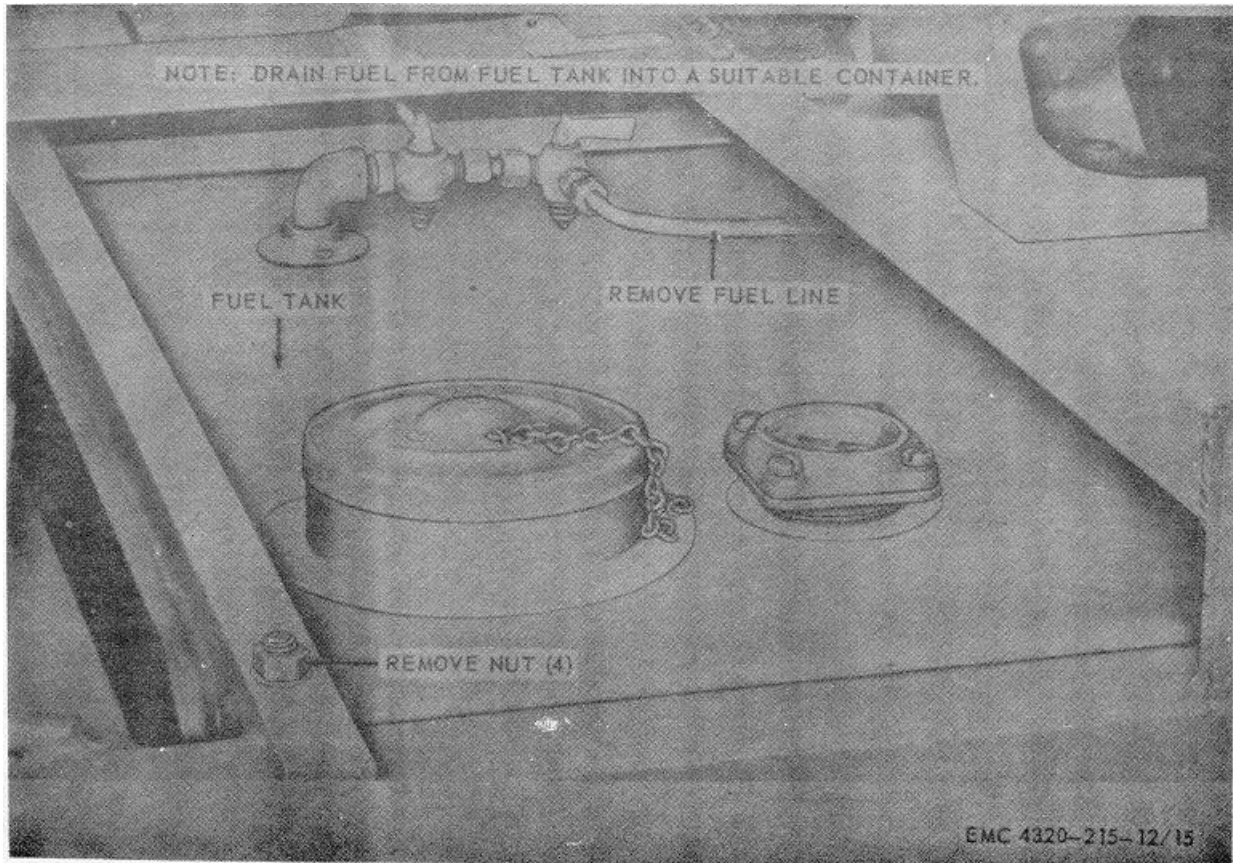
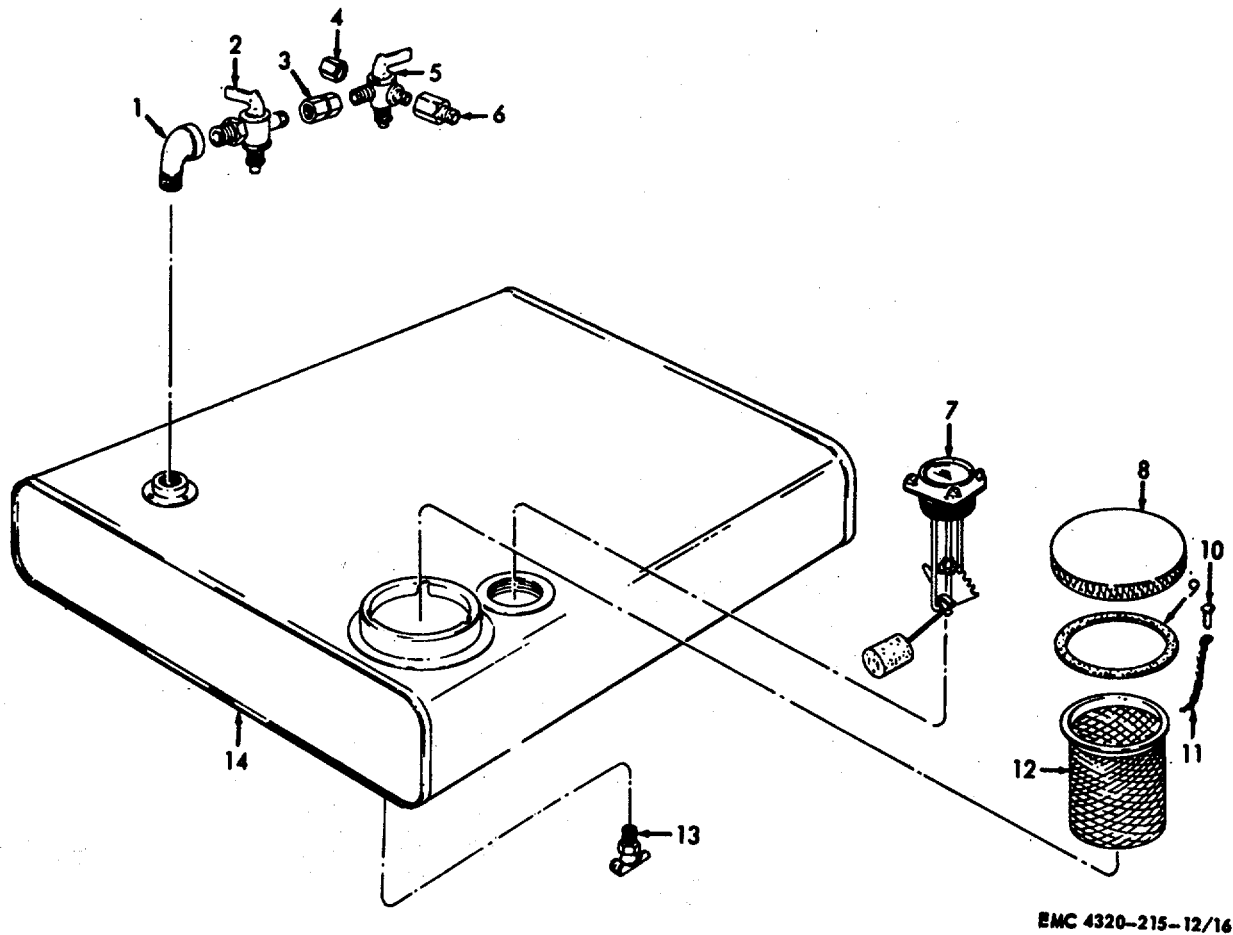

Figure 15. Fuel tank and fuel line, removal and installation.



- | | |
|------------------------|-----------------|
| 1 Elbow | 8 Fuel tank cap |
| 2 Fuel shutoff valve | 9 Gasket |
| 3 Line assembly | 10 Rivet |
| 4 Pipe cap | 11 Chain |
| 5 Auxiliary fuel valve | 12 Strainer |
| 6 Adapter | 13 Draincock |
| 7 Fuel gage | 14 Fuel tank |

Figure 16. Fuel tank, disassembly and reassembly.

Section VII. ELECTRICAL SYSTEM

48. General

The engine is equipped with 2 batteries, each with an output of 12 volts. The batteries are connected in series, thus producing a 24-v negatively grounded electrical system. The batteries are normally kept in a fully charged condition by a belt-driven, air-cooled generator. The generator output is controlled by a voltage regulator. The engine is also equipped with a starter which is energized by the engine start switch.

Engine ignition is accomplished by the use of a magneto.

49. Generator Drive Belt and Guard

a. Remove and install the generator belt guard as shown by figure 17.

b. Adjust, remove, and install the generator drive belt as shown by figure 18.

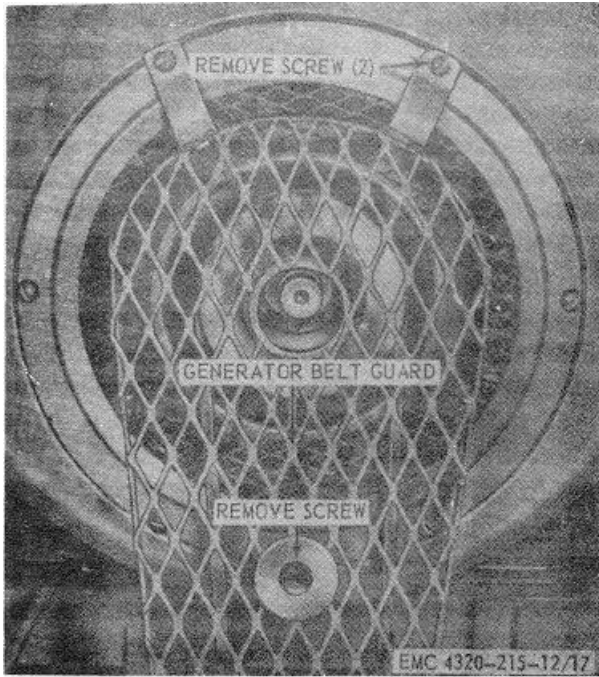

Figure 17. Generator belt guard, removal and installation.

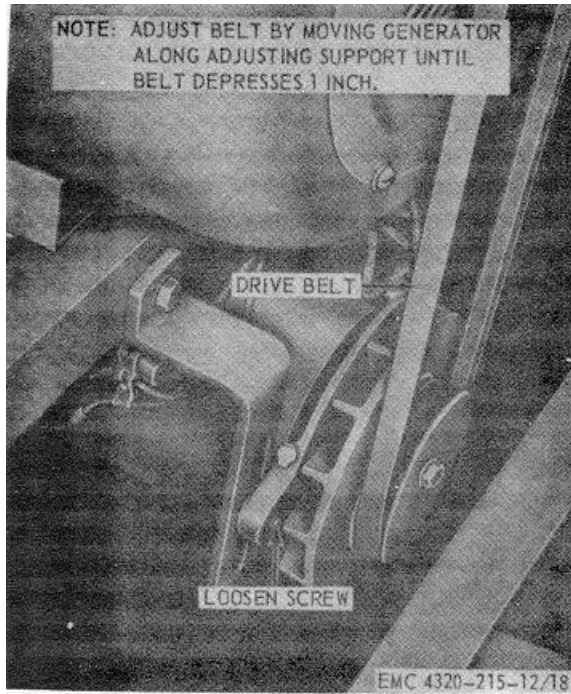

Figure 18. Generator drive belt, adjustment, removal, and installation.

50. Generator and Adjusting Support

a. Defects in the battery-charging system are indicated by a high-charging rate when the batteries are fully charged or by a low-charging rate when the batteries are low. In the event that trouble develops in the battery-charging system, perform the on-engine testing of the generator and voltage regulator as shown by figure 19.

b. Remove and install the generator belt guard and belt (par. 49).

c. Remove and install the generator and adjusting support as shown by figure 20.

51. Voltage Regulator and Shield Box

a. Refer to figure 19 for on-engine testing of the voltage regulator.

b. Remove and install the voltage regulator and shield box as shown by figure 21.

c. Clean and inspect the voltage regulator as shown by figure 22.

d. Perform the voltage regulator continuity test as shown by figure 23.

e. *Mechanical Adjustment.* Mechanical adjustment must be made with the voltage regulator off the unit. Adjust the voltage regulator as shown by figure 24.

f. *Electrical Adjustment.* A low voltage test set including a voltmeter, ammeter, fixed and variable resistors, carbon pile, and suitable switching devices, should be used to make the electrical adjustments on the voltage regulator. Mount the voltage regulator in operating position on or near the unit. Electrically adjust the voltage regulator as shown by figure 25.

Note

In the following procedures, the generator frame, the voltage regulator base, and the battery ground terminal must be connected to each other or a common ground.

g. *Testing after Adjustment.* Install the voltage regulator cover and test the operation of the three units at room temperature. Repeat adjustment procedures as necessary until the settings cease to drift. Replace the voltage regulator if it fails to respond to adjustment.

Caution

Do not adjust the setting of the current regulator unit above the rated output of the battery-charging generator.

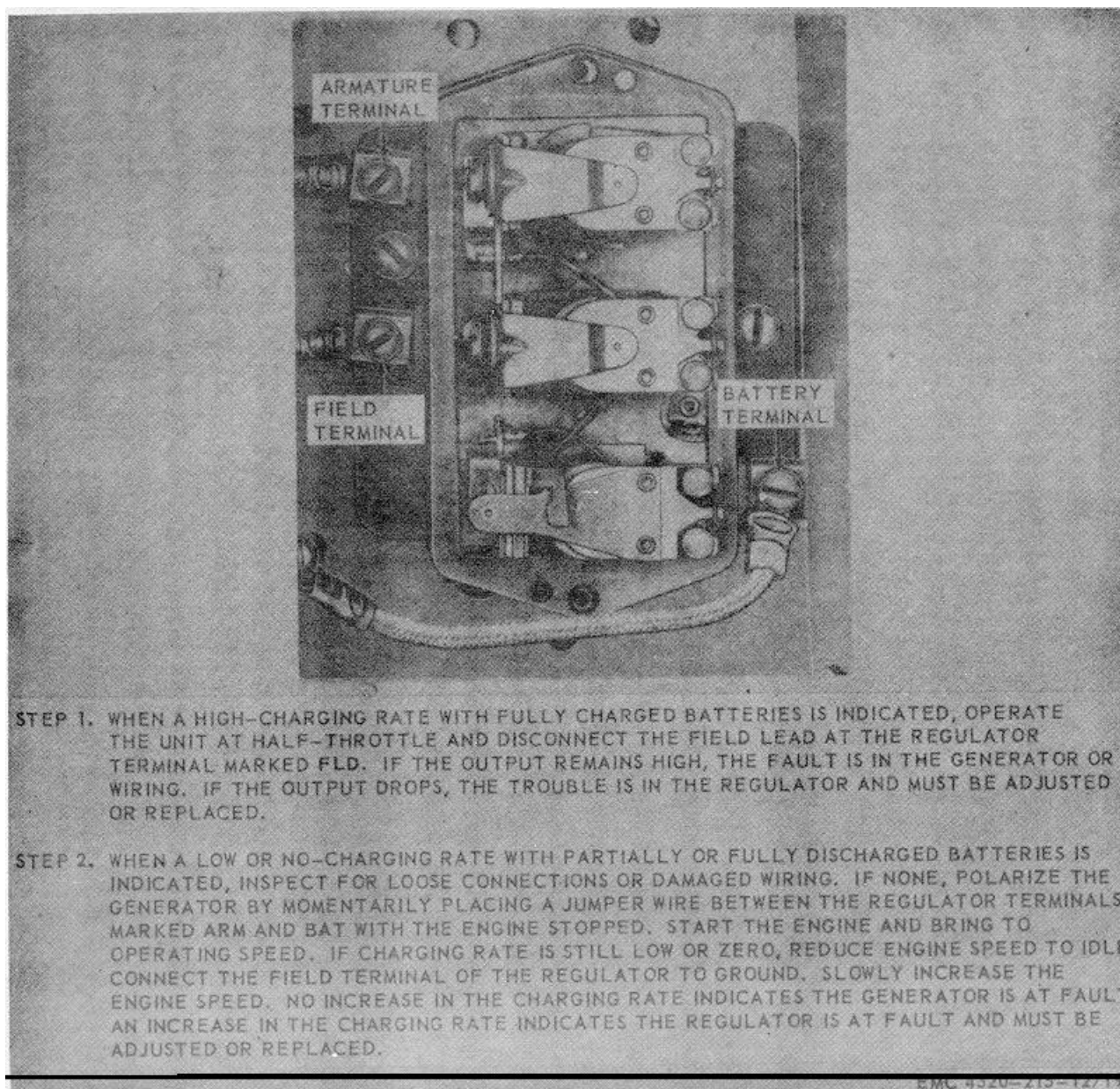

Figure 19. Generator and voltage regulator, on-engine testing.

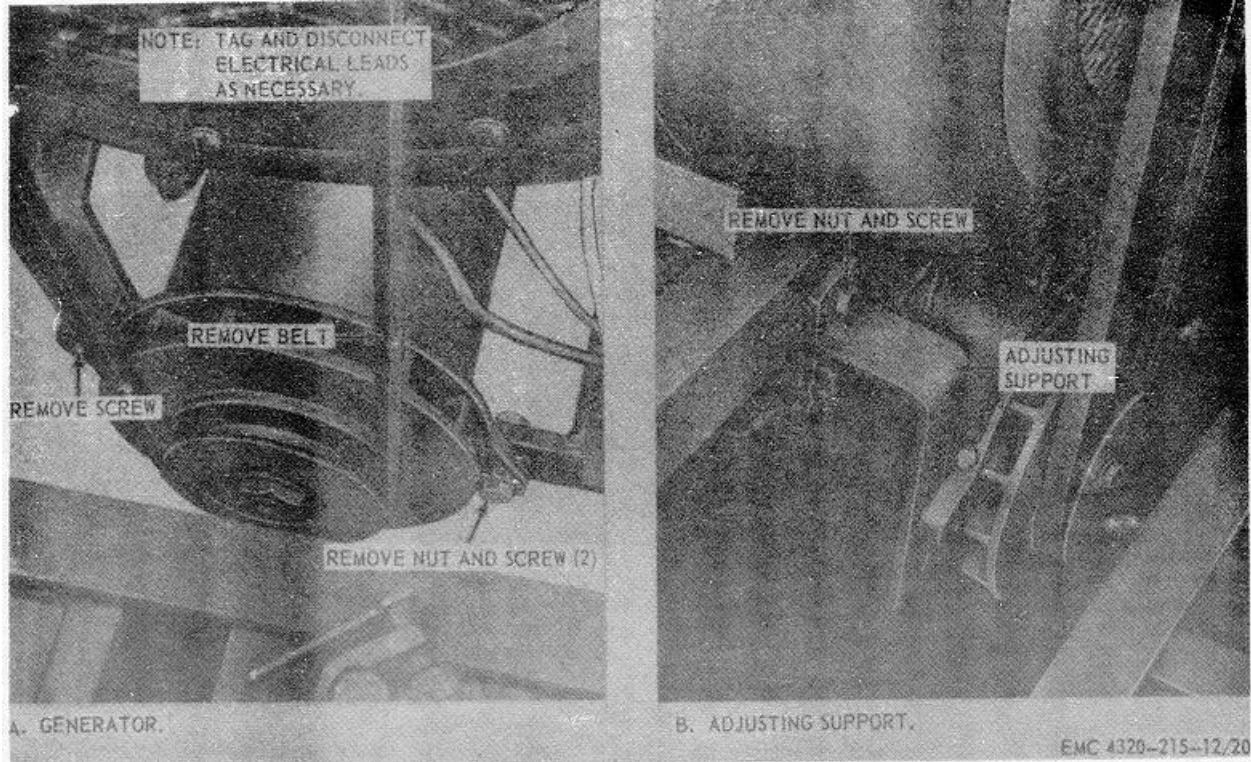

Figure 20. Generator and adjusting support, removal and installation.

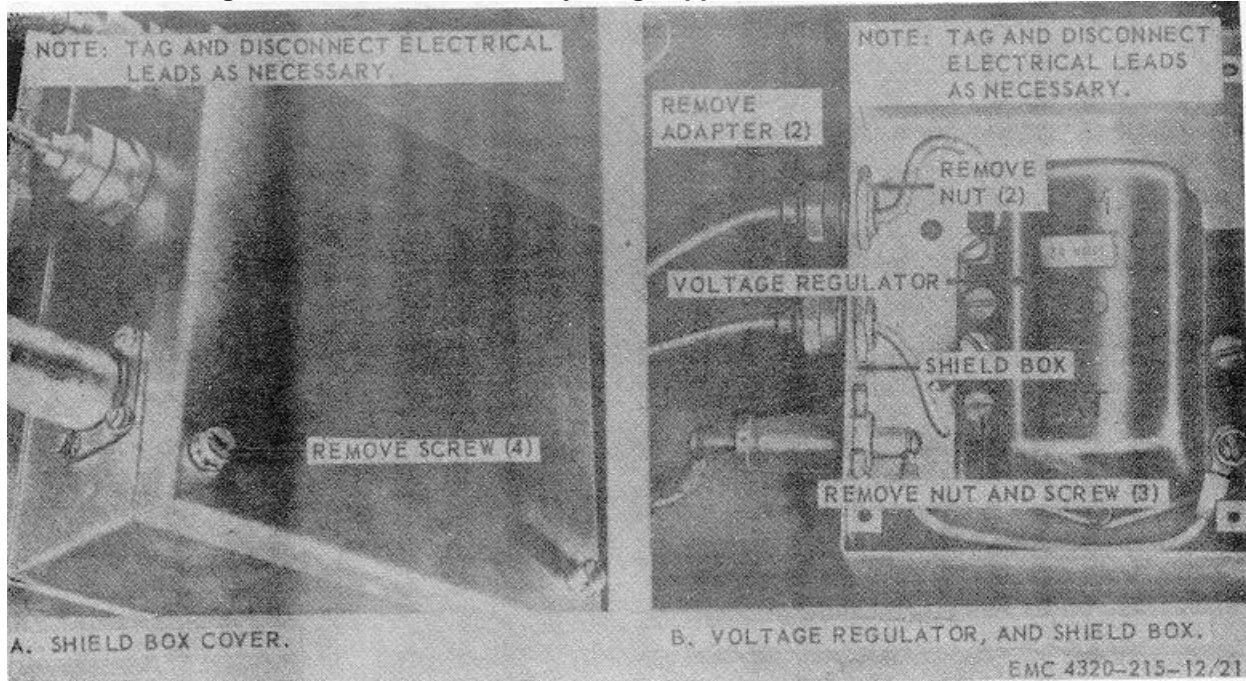

Figure 21. Voltage regulator and shield box, removal and installation.

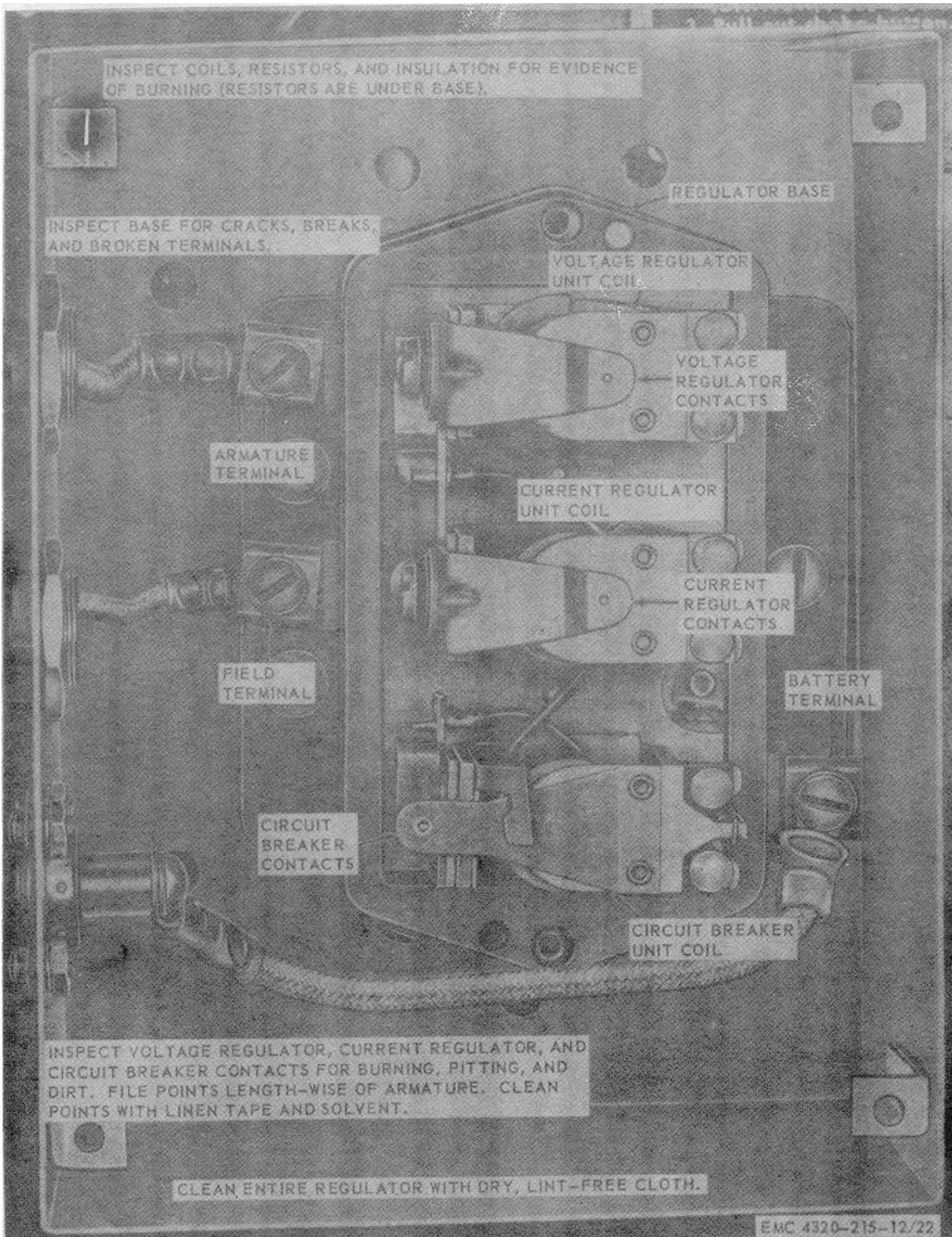

Figure 22. Voltage regulator, cleaning and inspection.

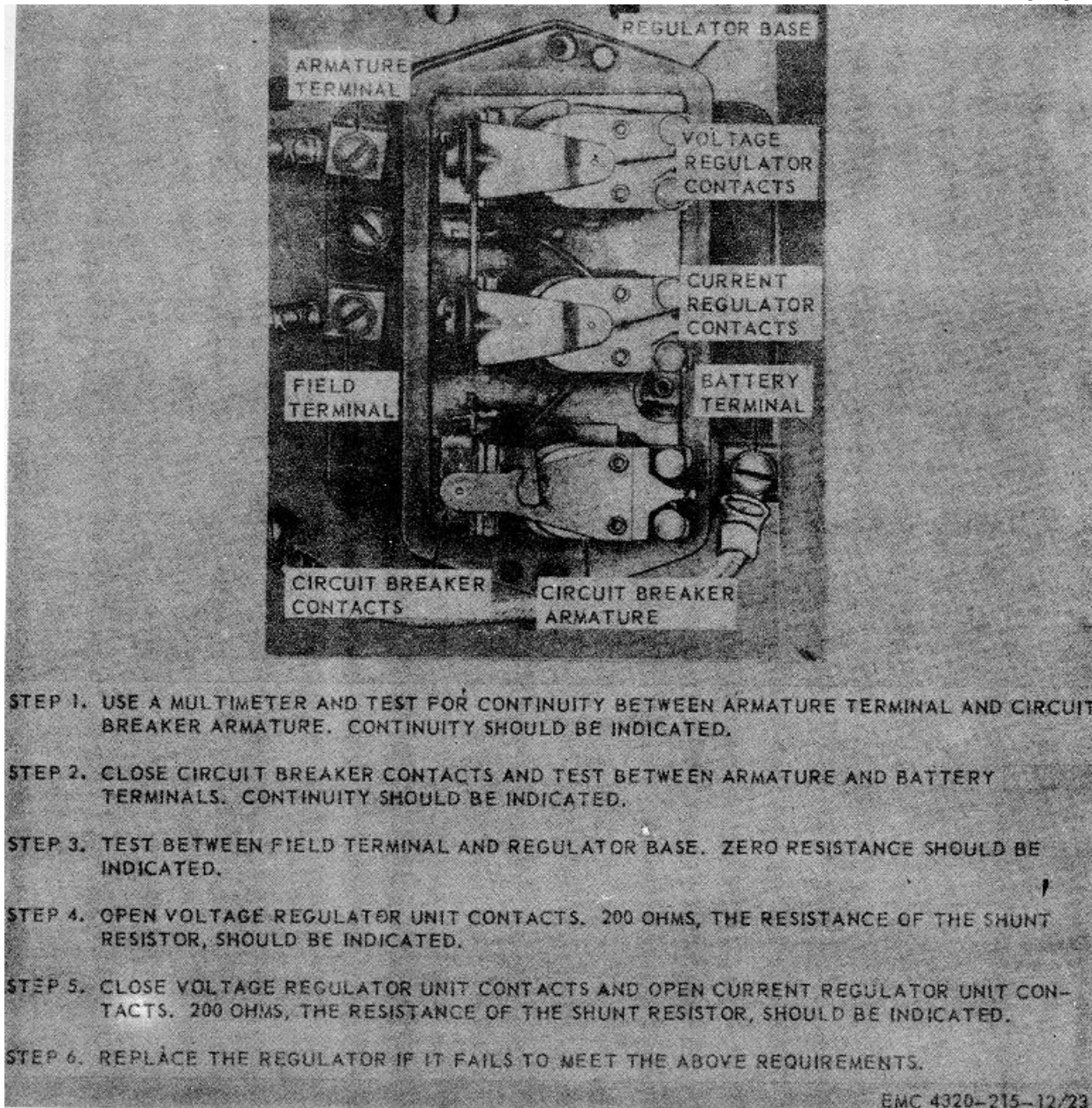
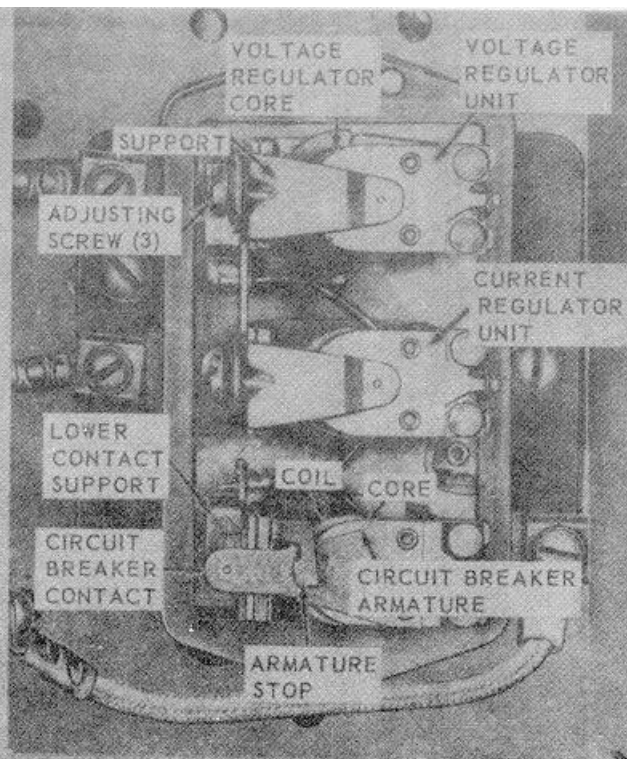

Figure 23. Voltage regulator continuity test.



- STEP 1. PRESS DOWN ON CIRCUIT BREAKER ARMATURE UNTIL POINTS JUST CLOSE. MEASURE AIR GAP BETWEEN ARMATURE AND CORE. GAP SHOULD BE BETWEEN 0.034 AND 0.040 INCH.
- STEP 2. BEND LOWER CONTACT SUPPORT TO OBTAIN DESIRED AIR GAP.
- STEP 3. MEASURE THE CIRCUIT BREAKER UNIT CONTACT GAP WITH A FEELER GAGE. IT SHOULD MEASURE 0.015 INCH MINIMUM.
- STEP 4. ADJUST CONTACT GAP IF NECESSARY BY BENDING UPPER ARMATURE STOP.
- STEP 5. MEASURE THE VOLTAGE REGULATOR UNIT CORE GAP BETWEEN ARMATURE AND CORE WITH FEELER GAGE. IT SHOULD MEASURE BETWEEN 0.048 AND 0.052 INCH.
- STEP 6. LOOSEN ONE UPPER CONTACT SUPPORT ATTACHING SCREW AND RAISE OR LOWER THE SUPPORT TO OBTAIN THE DESIRED GAP. TIGHTEN SCREW AND REMEASURE CORE GAP.
- STEP 7. ADJUST CURRENT REGULATOR UNIT IN THE SAME MANNER AS THE VOLTAGE REGULATOR UNIT (STEPS 5 AND 6). THE CORRECT CORE GAP IS BETWEEN 0.048 AND 0.052 INCH.

EMC 4320-215-12/24

Figure 24. Voltage regulator mechanical adjustment.

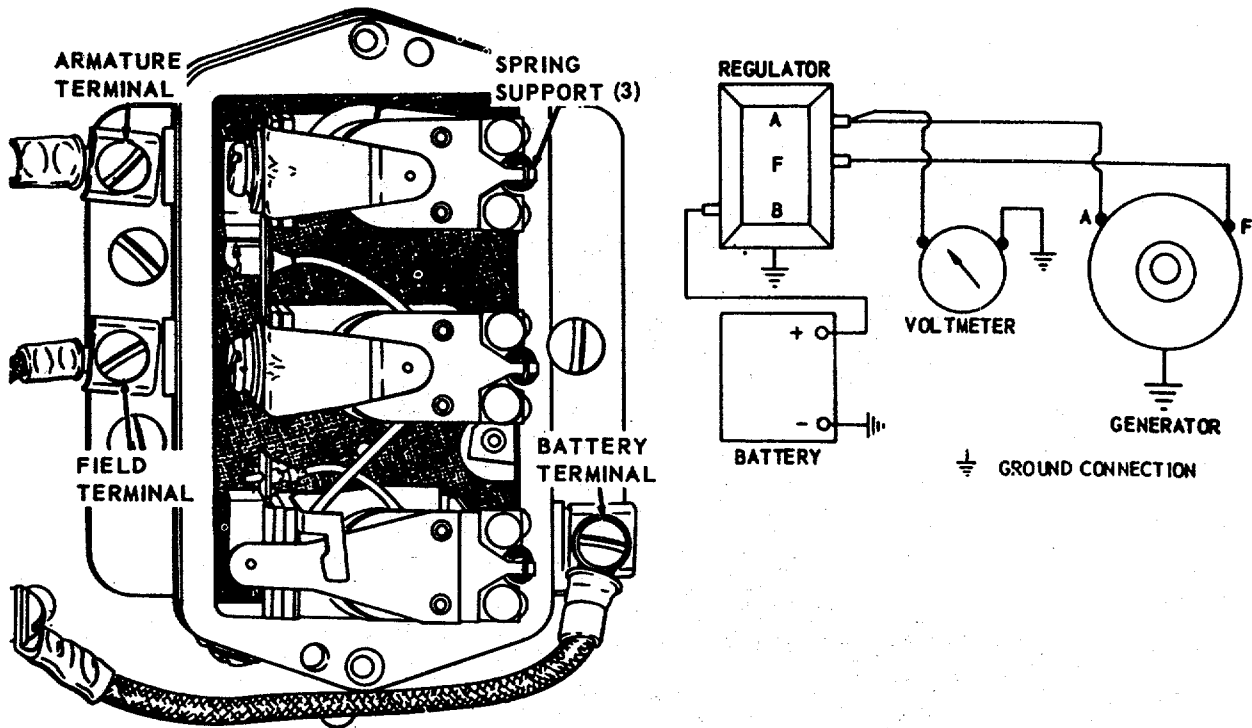

- STEP 1. CONNECT THE REGULATOR AS SHOWN ABOVE.**
- STEP 2. POLARIZE THE GENERATOR BY MOMENTARILY PLACING A JUMPER ACROSS THE ARMATURE AND BATTERY TERMINALS.**
- STEP 3. START THE UNIT AND SLOWLY INCREASE THE SPEED. THE CIRCUIT BREAKER CONTACTS SHOULD CLOSE AT 25 VOLTS.**
- STEP 4. BEND DOWN THE LOWER SPRING SUPPORT TO INCREASE THE CLOSING VOLTAGE AND UP TO INCREASE IT.**
- STEP 5. STOP THE UNIT.**

EMC 4320-215-12/25 ①

Figure 25. Voltage regulator electrical adjustment.

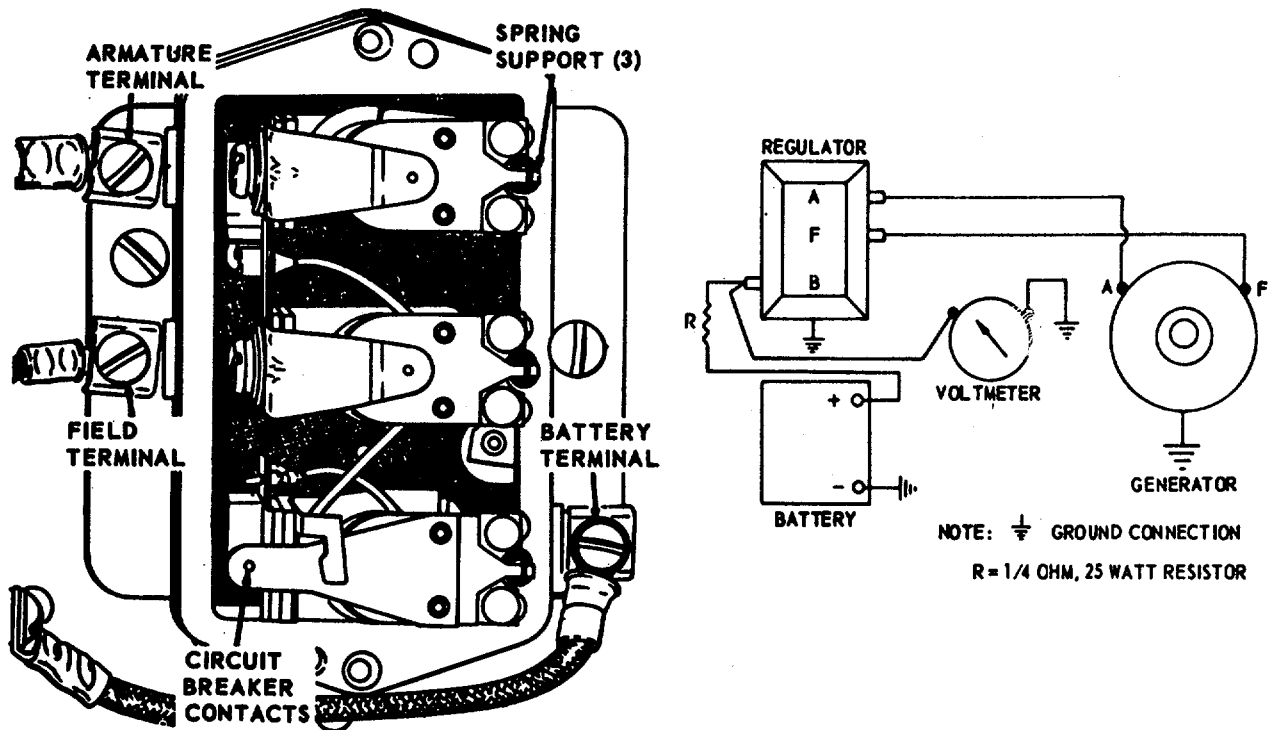

- STEP 1. CONNECT THE GENERATOR AS SHOWN ABOVE.**
- STEP 2. POLARIZE THE GENERATOR BY MOMENTARILY PLACING A JUMPER ACROSS THE ARMATURE AND BATTERY TERMINALS.**
- STEP 3. START UNIT AND OPERATE AT GOVERNED SPEED FOR 15 MINUTES. THE VOLTMETER SHOULD INDICATE 28.3 VOLTS AT A SURROUNDING TEMPERATURE OF 80°F.**
- STEP 4. REMOVE THE REGULATOR COVER AND BEND THE LOWER SPRING SUPPORT DOWN TO INCREASE THE VOLTAGE SETTING AND UP TO DECREASE IT.**
- STEP 5. AFTER EACH ADJUSTMENT, INSTALL THE COVER, REDUCE THE SPEED UNTIL THE CIRCUIT BREAKER CONTACTS OPEN, THEN BRING THE UNIT SLOWLY UP TO OPERATING SPEED.**
- STEP 6. REPEAT STEPS 4 AND 5 UNTIL THE VOLTAGE SETTING REMAINS CONSTANT.**
- STEP 7. STOP THE UNIT.**

EMC 4320-215-12/25 (2)

Figure 25. Continued.

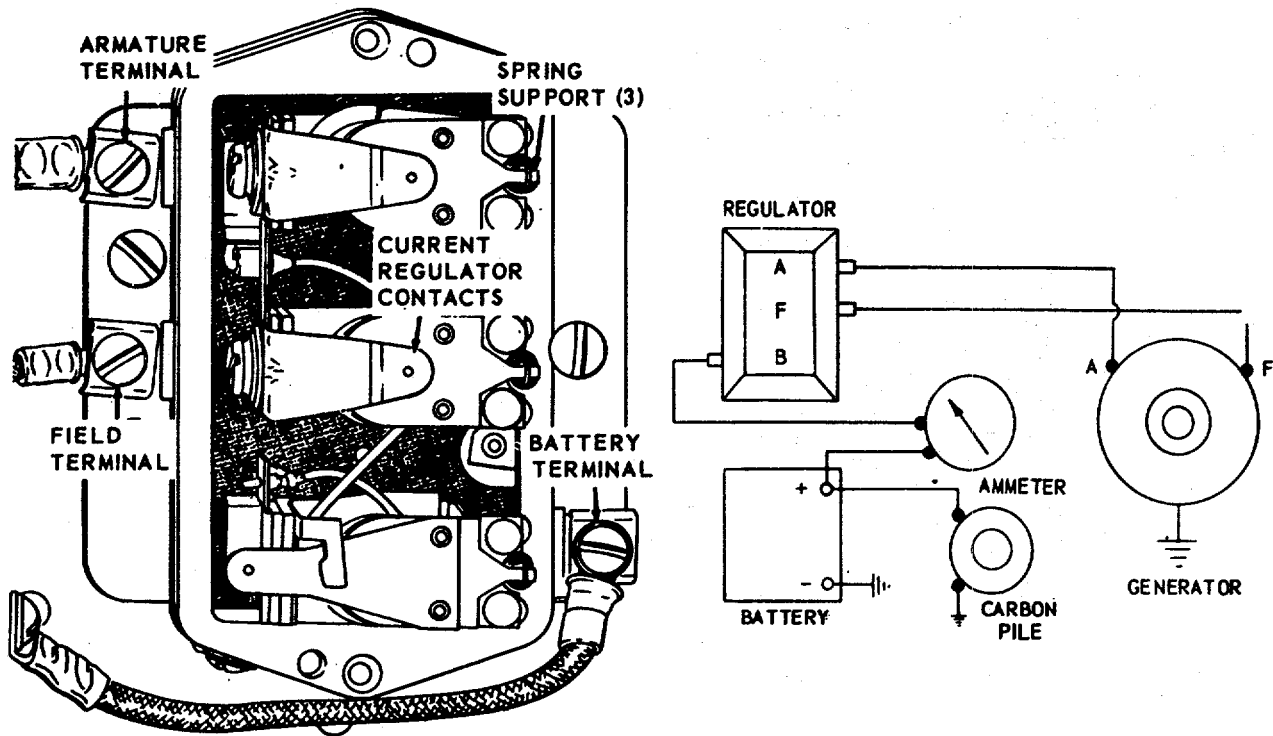

- STEP 1. CONNECT THE REGULATOR AS SHOWN ABOVE.**
- STEP 2. POLARIZE THE GENERATOR BY MOMENTARILY PLACING A JUMPER ACROSS THE ARMATURE AND BATTERY TERMINALS.**
- STEP 3. START THE UNIT AND OPERATE AT GOVERNED SPEED FOR 15 MINUTES.**
- STEP 4. REMOVE THE REGULATOR COVER AND MANUALLY CLOSE THE CURRENT REGULATOR CONTACTS.**
- STEP 5. ADJUST THE CARBON PILE UNTIL THE AMMETER INDICATES 20 AMPERES.**
- STEP 6. RELEASE THE CONTACTS AND BEND DOWN THE LOWER SPRING SUPPORT TO INCREASE THE CURRENT SETTING AND UP TO DECREASE IT UNTIL THE AMMETER INDICATES 18 AMPERES.**
- STEP 7. STOP THE UNIT.**

EMC 4320-215-12/25

Figure 25. Continued.

Caution

The battery-charging generator must be polarized whenever the leads to the generator or voltage regulator have been removed or any adjustments have been made to the generator or voltage regulator. Failure to polarize the generator may cause the regulator contacts to be damaged by vibration, heavy arcing, and burning.

Caution

Do not close the contacts of the circuit breaker unit by hand while the batteries are connected. The resultant high current will damage the contacts.

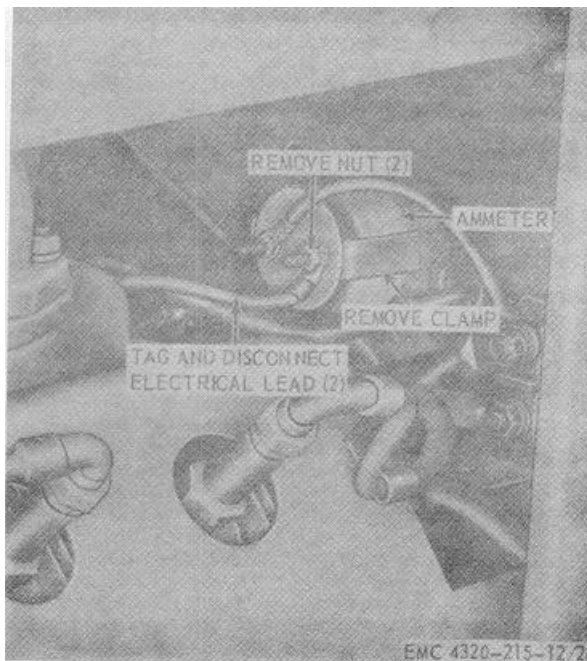

Figure 16. Ammeter and clamp, removal and installation.

52. Ammeter and Clamp

- a. Remove and install the ammeter and clamp as shown by figure 26.
- b. Clean and inspect.

53. Battery Cables and Battery Box

- a. Remove and install the battery cables and battery box as shown by figure 4.
- b. Clean and inspect.

Section VIII. LUBRICATION SYSTEM**54. General**

This section includes maintenance instructions on the lubrication system components not covered in TM 5-2805-209-12. For operator and organizational maintenance on engine lubrication, refer to TM 5-2805-209-12.

55. Grease Cup, Reducer, and Nipple

- a. Remove and install the grease cup, reducer, and nipple as shown by figure 12.
- b. Clean and inspect.

Section IX. LUNETTE, TONGUE, LIFTING BAIL, CART FOOT, REFLECTORS, WHEEL CHOCKS, CRANK HOLDDOWN BRACKET, AND FIRE EXTINGUISHER BRACKET**56. General**

The engine of the pumping unit is completely enclosed in a sheet metal housing with doors provided for easy access to all components. This section covers maintenance of the lunette, tongue, lifting bail, cart foot, reflector, wheel chocks, crank holddown bracket, and fire extinguisher bracket. Refer to TM 5-2805-209-12 for maintenance of the housing.

57. Tongue and Cart Foot

- a. Remove and install the tongue and cart foot as shown by figure 27.
- b. Clean and inspect.

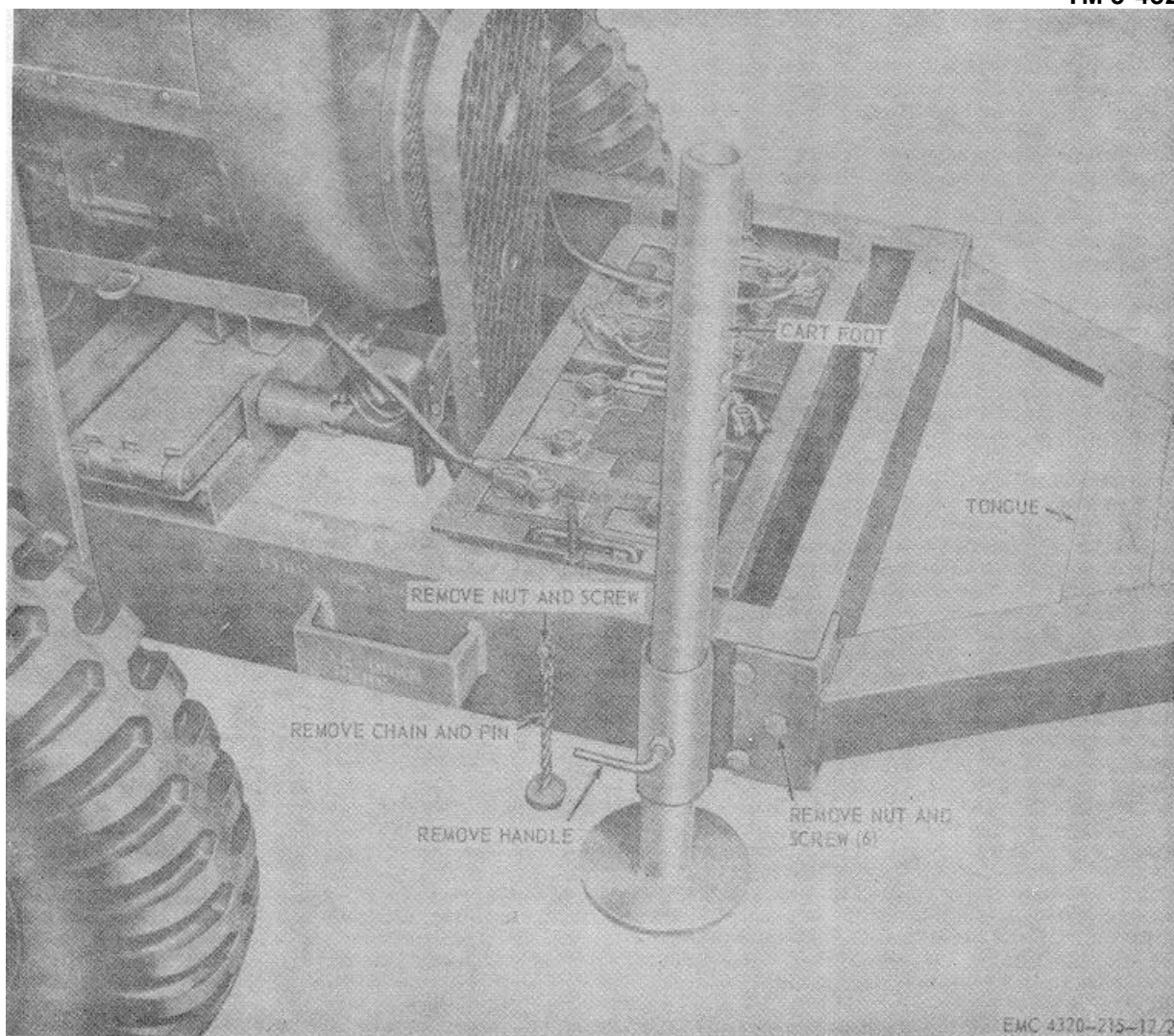

Figure 27. Tongue and cart foot, removal and installation

58. Reflector, Wheel Chock, Lynette, and Lifting Bail

- a. Remove and install the reflector, wheel chock, lunette, and lifting bail as shown by figure 28.
- b. Clean and inspect.

59. Crank Holddown Bracket and Fire Extinguisher Bracket

- a. Remove and install the crank holddown bracket and fire extinguisher bracket as shown by figure 29.
- b. Clean and inspect.

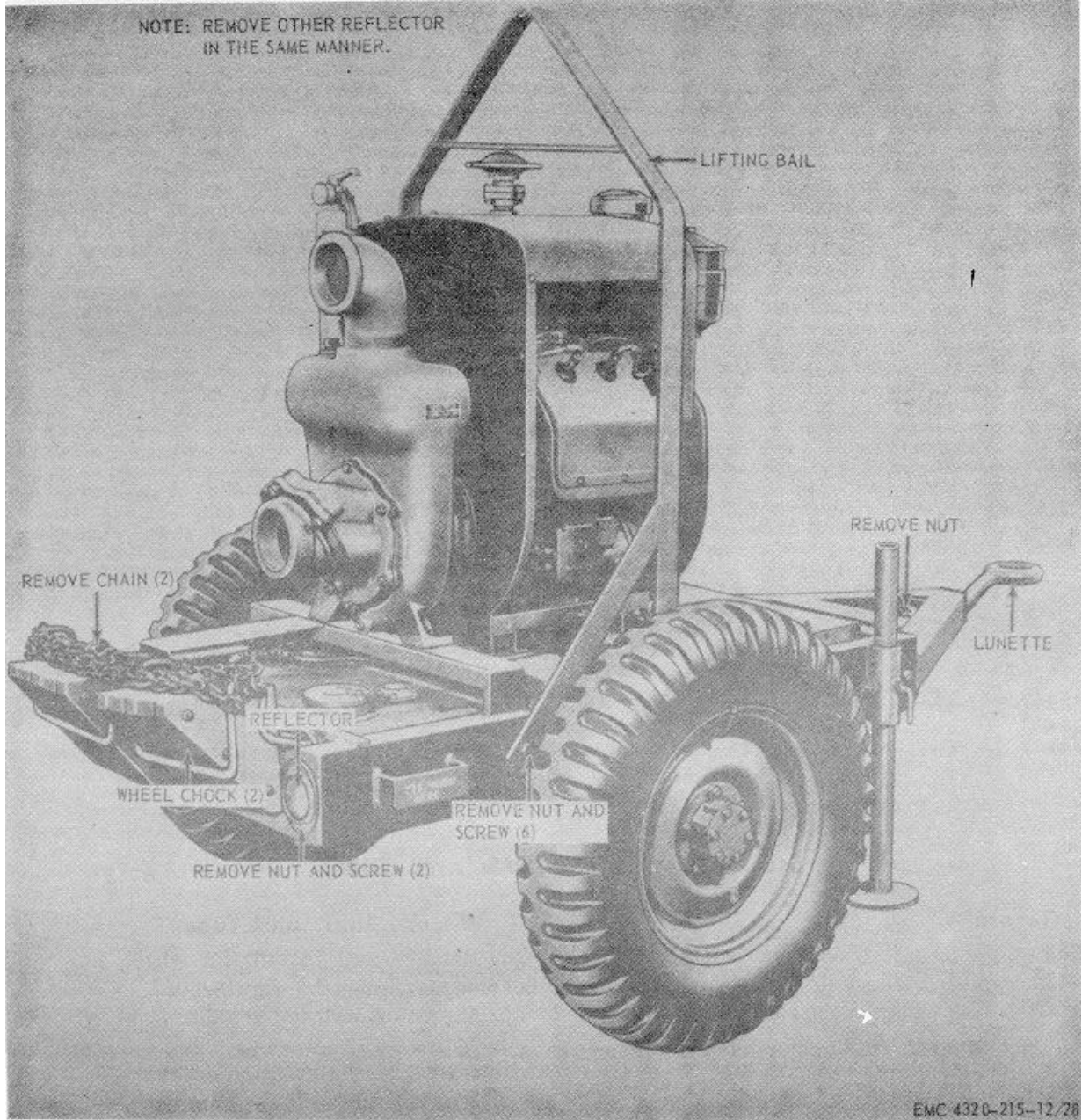

Figure 18. Reflector, wheel chock, lunette, and lifting bail, removal and installation

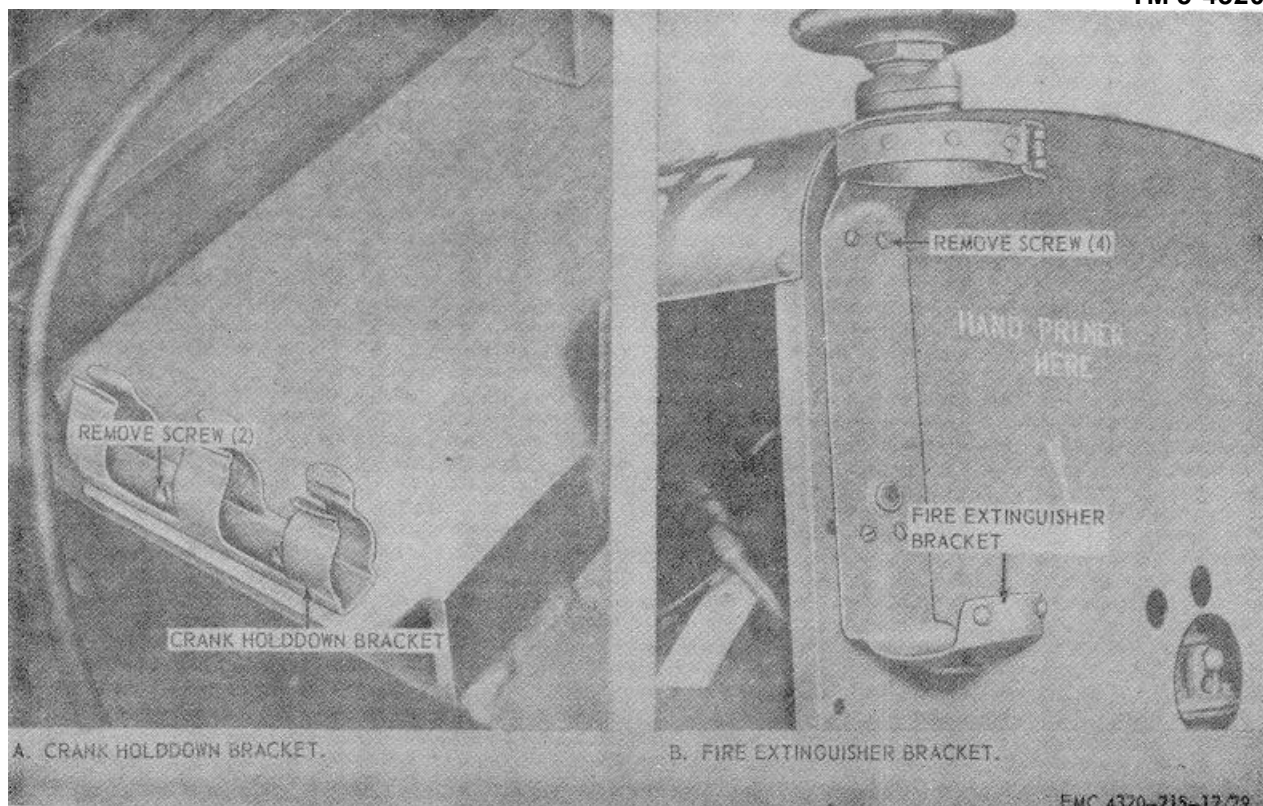

Figure 29. Crank holddown bracket and fire extinguisher bracket, removal and installation.

Section X. WHEELS, TIRES, AND TUBES

60. General

The pumping unit is equipped with two rubber tire mounted wheels for use in moving the unit from one worksite to another. Refer to TM 9-1870-i for care and maintenance of pneumatic tires.

61. Wheels, Tires, and Tubes

- a. Remove and install the wheel, hub, and bearing as shown by figure 30.
- b. Clean, inspect and repair.
- c. Lubricate the wheel bearing in accordance with the current lubrication order.
- d. Disassemble and reassemble the wheels, tires, and tubes as shown by figure 31.

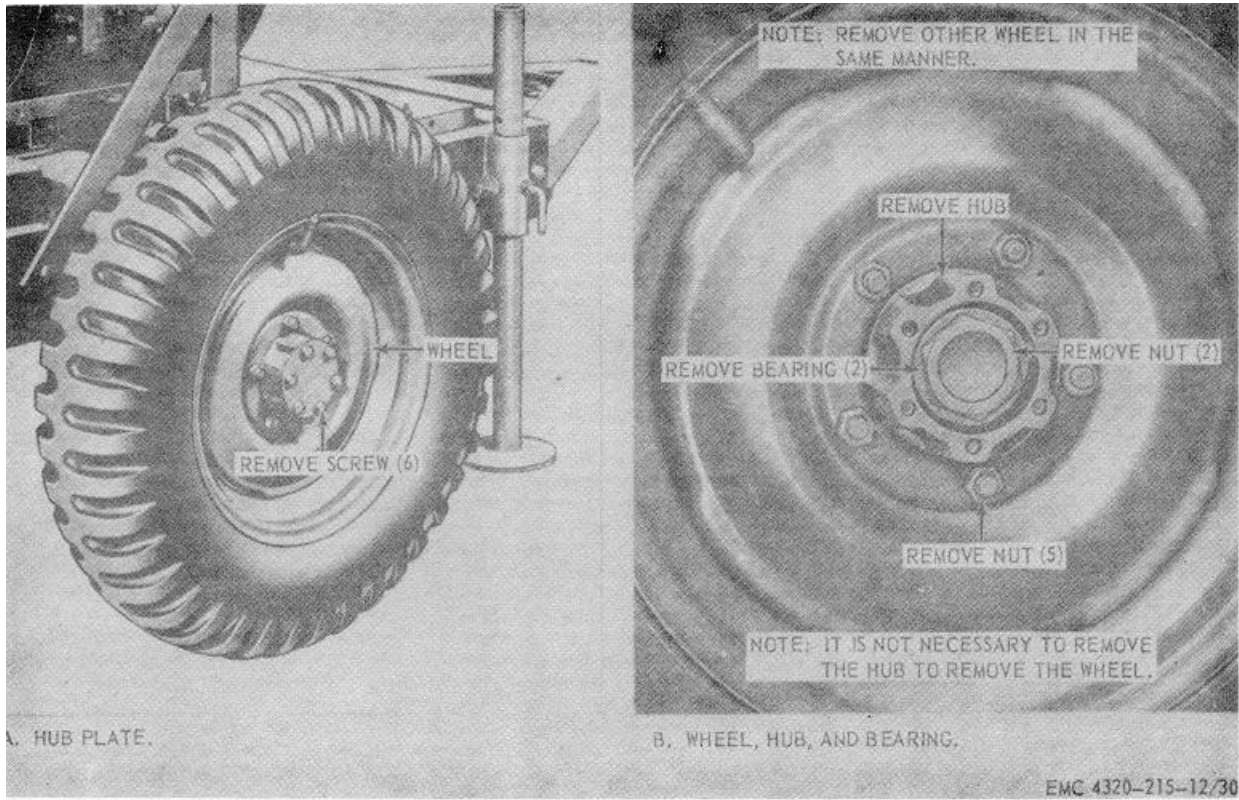
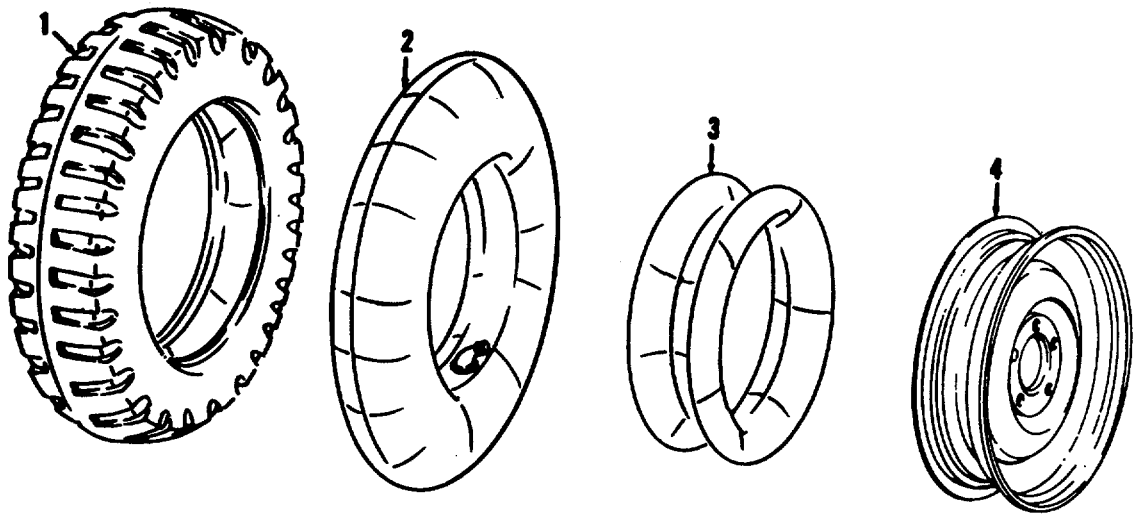

Figure 20. Wheel, hub, and bearing, removal and installation.



EMC 4320-215-12/31

1 Tire

2 Tube

3 Flap

4 Wheel

Figure 31. Wheels, tires, and tubes, disassembly and reassembly.

CHAPTER 4
DEMOLITION OF THE PUMPING UNIT TO PREVENT ENEMY USE

62. General

When capture or abandonment of the pumping unit to an enemy is imminent, the responsible unit commander must make the decision either to destroy the equipment or to render it inoperative. Based on this decision, orders are issued which cover the desired extent of destruction. Whatever method of demolition is employed, it is essential to destroy the same vital parts of all pumping units and all corresponding repair parts.

63. Demolition To Render Pumping Unit Inoperative

a. Mechanical Means. Use sledge hammers, crowbars, picks, axes, or other heavy tools which may be available to destroy the following:

- (1) Engine crankcase and manifolds.
- (2) Carburetor, magneto, and governor.
- (3) Shroud, starter, and generator.

Note

The above steps are minimum requirements for this method.

- (4) Pump chamber.
- (5) All controls and instruments.

b. Misuse. Drain the engine crankcase. Pour sand, gravel, bolts, screws, or broken glass into the fuel tank, oil filler pipe, and pump priming hole.

64. Demolition by Explosives or Weapons Fire

a. Explosives. Place as many of the following charges (fig. 82) as the situation permits and detonate t

them simultaneously with detonating cord and a suitable detonator.

b. Weapons Fire. Fire on the pumping unit with the heaviest practical weapons available.

65. Other Demolition Methods

a. Scattering and Concealment. Remove all easily accessible parts such as the carburetor, fuel pump, magneto, generator, and starter and scatter them through dense foliage, bury them in dirt, or sand, or throw them in a lake, stream, or other body of water.

b. Burning. Pack rags, clothing, or canvas under and around the unit. Saturate this packing with gasoline, oil, or diesel fuel and ignite.

c. Submersion. Totally submerge the unit in a body of water to provide water damage concealment. A body of salt water will do greater damage to metal parts than submersion in a body of fresh water.

66. Training

All operators should receive thorough training in the destruction of the pumping unit. Refer to TM 5-25. Simulated destruction, using all of the methods listed above, should be included in the operator training program. It must be emphasized in training, that demolition operations are usually necessitated by critical situations when time available for carrying out destruction is limited. For this reason, it is necessary that operators be thoroughly familiar with a! methods of destruction of equipment, and be able to carry out demolition instructions without reference to this or any other manual.

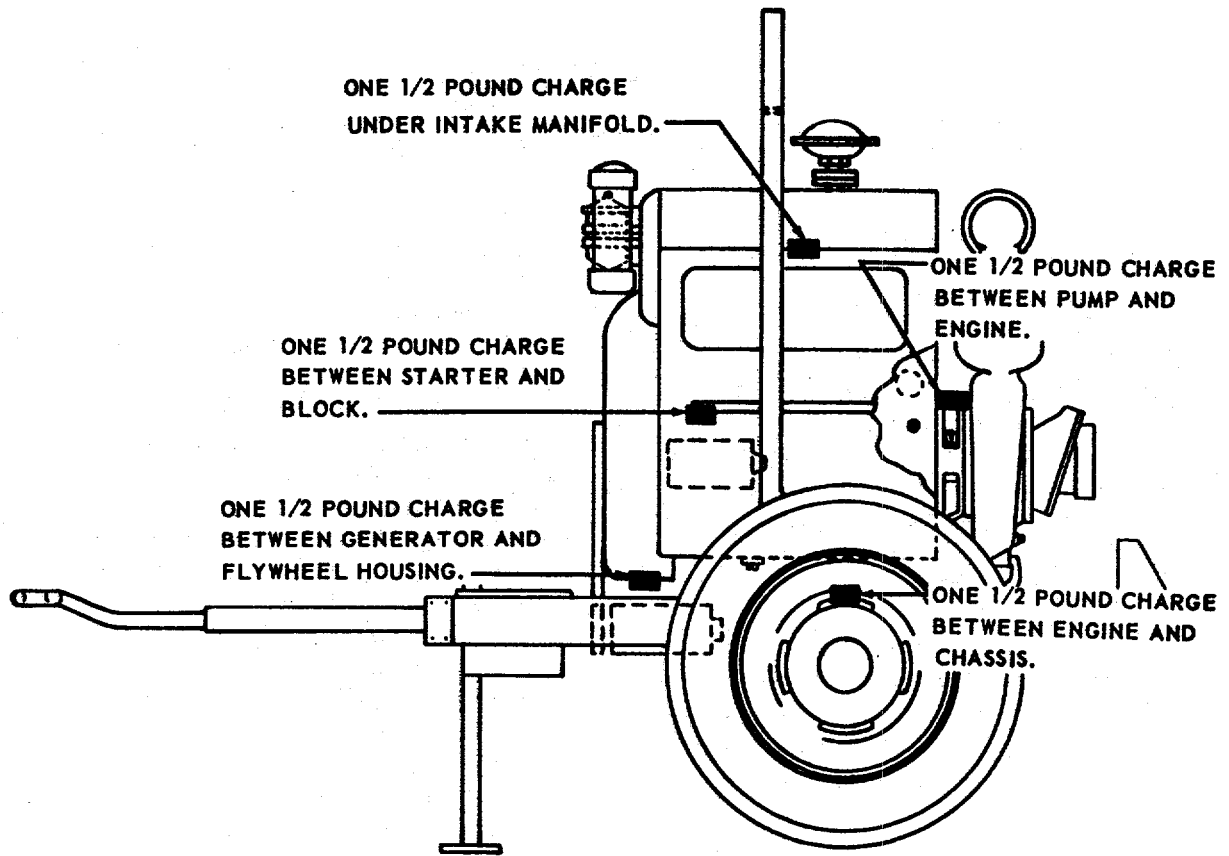

LEGEND: ■ 1/2 POUND CHARGE

EMC 4320-215-12/32

Figure 32. Placement of charges.

CHAPTER 5 SHIPMENT AND LIMITED STORAGE

Section I. SHIPMENT WITHIN ZONE OF INTERIOR

67. Preparation of Equipment for Shipment

- a. Clean the pumping unit with an approved cleaning solvent.
- b. Drain the fuel tank (par. 47). Operate the engine until the fuel in the system is completely used.
- c. Drain the lubrication system and air cleaner (TM 5-2805-209-12).
- d. Disconnect the batteries and battery jumper cable (par. 12). Tape the battery jumper cable to the inside of the battery box cover.
- e. Tag all items requiring special attention before the unit can be operated.

f. Refer to the basic issue items list (app. III) and make sure that all tools and publications therein listed are on, or with, the pumping unit and in serviceable condition.

g. Refer to TM 9-T00 for preservation, packaging, packing, and shipping instructions.

68. Loading Equipment for Shipment

a. Hoist the pumping unit with a sling or hook attached to the lifting bail. For lifting instructions, refer to paragraph 7. When towing, make sure that the cart foot is in the travel position.

b. Secure the pumping unit to the bed of the carrier by means of blocks and tiedown cables, to prevent shifting during transportation.

Section II. LIMITED STORAGE

69. Preparation of Equipment for Storage

- a. *Inspection.* Make a complete inspection of the pumping unit using the quarterly preventive maintenance services (par. 88) as a guide.
- b. *Cleaning and Painting.* Clean the pumping unit and all components that are accessible without disassembly. Remove any accumulated water, oil, or grease from inside the frame of the unit. Remove all rust and corrosion. Paint all parts on which the paint film has been damaged or removed. Refer to TM 9-2851.
- c. *Lubrication.* Lubricate the pumping unit in accordance with the current lubrication order.
- d. *Protection.* In extremely cold climates, disconnect the batteries and remove them. Clean the battery terminals and cable connectors and apply a

coating of grease or Vaseline. Pack or store the batteries separately in a warm, dry place. If the batteries must remain in the unit, keep them filled and fully charged at all times.

70. Inspection and Maintenance of Equipment in Storage

a. *Inspection.* When equipment has been placed in storage, all scheduled preventive maintenance services, including inspection, will be suspended and preventive maintenance inspection will be performed as specified herein. Refer to AR 743-506.

b. *Worksheet and Preventive Maintenance.* DA Form 464 will be executed on each major item of equipment when equipment is initially

placed in limited storage and every 30 days thereafter. Required maintenance will be performed promptly to insure that the equipment is mechanically sound and ready for immediate use.

c. Operation. Equipment in limited storage must be operated long enough to bring it up to operating temperature and for complete lubrication of all bearings, gears, and so on, at least every 30 days. Equipment must be serviced and in satisfactory operating condition before it is operated.

APPENDIX I REFERENCES

1. Dictionaries of Terms and Abbreviations

AR 320-5 Dictionary of United States Army Terms.
AR 320-50 Authorized Abbreviations and Brevity Codes.

2. Lubrication

LO 5-4320-215-12 Pump, Centrifugal: Fresh Water; Gasoline Driven; 2 Wheel Mounted;
4 In.; 500 Gpm, 80 Ft. Read (Carver Model K400S) FSN 4320-810-
7811 (Less Engine).

3. Painting

TM 9-2851 Painting Instructions for Field Use.

4. Preventive Maintenance

AR 700-38 Unsatisfactory Equipment Report.
TM 5-2805-209-12 Operator and Organizational Maintenance Manual
Engine, Gasoline (Wisconsin Model MVF4D).
TM 9-1870-1 Care and Maintenance of Pneumatic Tires.
AR 750-5 Maintenance Responsibilities and Shop Operations.
TM 5506 Maintenance of Engineer Equipment.
TM 9-6140-200-15 Storage Batteries, Lead-Acid Type.

5. Publication Indexes

DA Pam 108-1 Index of Army Motion Pictures, Film Strips, Slides, and Phono-recordings.
DA Pam 810-1 Index of Administrative Publications.
DA Pam 310-2 Index of Blank Forms.
DA Pam 810-8 Index of Training Publications.
DA Pam 310-4 Index of Technical Manuals, Technical Bulletins, Supply Bulletins, Lubri-
cation Orders, and Modification Work Orders.
DA Pam 810-5 Index of Graphic Training Aids and Devices.
DA Pam 810-25 Index of Supply Manual-Corps of Engineers.

6. Radio Interference Suppression

TM 11-488 Radio Interference Suppression.

7. Shipment and Limited Storage

AR 743-605 Limited Storage of Engineer Mechanical Equipment.
TM 9-200 General Packaging Instructions for Ordnance General Supplies.

8. Supply Publications

SM 10-1-C4-1

Petroleum, Petroleum-Base Products, and Related Materials.

9. Training Aids

FM 5-25

Explosives and Demolition.

FM 21-5

Military Training.

FM 21-6

Techniques of Military Instruction.

FM 2130

Military Symbols.

APPENDIX II MAINTENANCE ALLOCATION

1. General

This appendix contains a maintenance allocation chart listing all maintenance and repair operations authorized for the various echelons.

2. Maintenance

Maintenance is any action taken to keep materiel in a serviceable condition or to restore it to serviceability when it is unserviceable. Maintenance of materiel includes the following:

a. Service. To clean, to preserve, and to replenish fuel and lubricants.

b. Adjust. To regulate periodically to prevent malfunction.

c. Inspect. To verify serviceability and to detect incipient mechanical failure by scrutiny.

d. Test. To verify serviceability and to detect incipient mechanical failure by use of special equipment such as gages, meters, and so on.

e. Replace. To substitute serviceable assemblies, subassemblies, and parts for unserviceable components.

f. Repair. To restore an item to serviceable condition through correction of a specific failure or unserviceable condition. This function includes but is not limited to, inspecting, cleaning, preserving, adjusting, replacing, welding, riveting, and straightening.

g. Overhaul. To restore an item to *completely serviceable* condition as prescribed by serviceability standards developed and published by heads of technical services. This is accomplished through employment of the technique of "inspect and repair only as necessary" (IROAN). Maximum utilization of diagnostic and test equipment is combined with minimum disassembly of the item during the overhaul process.

3. Explanation of Columns

a. Functional Group. The functional group is a numerical group set up on a functional basis. The applicable functional grouping indexes are taken from the Corps of Engineers Functional Grouping Indexes, and appear on the Maintenance Allocation Chart in their correct numerical sequence. These indexes are normally set up according to their proximity to each other and their function.

b. Components and Related Operation. This column contains the functional index grouping heading, subgroup headings, and a brief description of the part starting with the noun name. It also designates the operation to be performed such as service, adjust, inspect, test, replace, repair, and overhaul.

c. Echelon Maintenance.

- (1). First echelon. First echelon maintenance is that maintenance performed by the user or operator of the equipment, such as servicing, cleaning, lubricating, and limited adjustments. It also includes removal and replacement of items to accomplish servicing and lubricating.
- (2). Second Echelon. Second echelon maintenance is that maintenance. Performed by trained personnel provided for that purpose in the using organization, such as replacement of all items in column 2, limited parts fabrication from bulk material, adjustments, and repair on assemblies, components, and end items that can be accomplished without extensive disassembly.
- (3). Third echelon. Third echelon maintenance is that maintenance performed by specially trained units in direct support of the using organization,

such as replacement of all items in columns 2 and 3, repair assemblies, components, and end items, and fabricate parts from bulk material.

(4) *Fourth echelon.* Fourth echelon maintenance is that maintenance performed by units organized as semi-fixed or permanent shops to serve lower echelon maintenance within a geographical area, such as replacement of items in columns 2, 3, and 4 repair end items, overhaul assemblies, components, and fabricate general use common hardware and parts.

(5) *Fifth echelon.* Fifth echelon maintenance is that maintenance authorized to overhaul assemblies,

components, end items, and replacement of all parts in columns 2, 3, 4, and 5.

d. *Symbol X.* The symbol X placed in the appropriate column indicates the lowest echelon responsible for performing that particular maintenance operation, but does not necessarily indicate repair parts will be stocked at that level.

e. *Remarks.* The remarks column is used to explain why maintenance, that would normally be done at a lower echelon, is moved to a higher echelon because of some peculiarity in the construction of the end item.

MAINTENANCE ALLOCATION CHART

Functional group	Components and related operation	Echelons of maintenance					Remarks
		1	2	3	4	5	
01 0100	ENGINE. Engine Assembly: Engine, gasoline: Service ----- Inspect ----- Test ----- Replace ----- Repair ----- Overhaul -----	X X -- -- -- --	-- -- X X -- --	-- -- -- -- X --	-- -- -- -- -- X	-- -- -- -- -- --	References: TM 5-2805-209-12 TM 5-2805-209-12 TM 5-2805-209-12 TM 5-2805-209-35 TM 5-2805-209-35
0111.1	Handcranking Devices: Clamp, hand crank: Replace -----	--	X				
08 0306	FUEL SYSTEM. Tanks Lines, Fittings: Tank, gasoline: Service ----- Repair ----- Line assembly: fuel: Replace -----	X -- -- --	-- -- X X	X -- --	-- -- -- --		
06 0601	ELECTRICAL SYSTEM (ENGINE AND VEHICULAR). Generator. Generator, engine accessory, electrical: Service ----- Test ----- Replace ----- Repair ----- Belt, V: Adjust ----- Replace -----	X -- -- -- -- X --	-- X X -- -- X X	-- -- -- X -- --	-- -- -- -- -- --	Fabricate. Install Kit.	

Functional group	Components and related operation	Echelons of maintenance					Remarks
		1	2	3	4	5	
0602	Generator Regulator: Regulator, engine generator: Adjust ----- Test ----- Replace -----		X X X				
0607	Instrument or Engine Control Panel: Ammeter: Replace ----- Lead, electrical: Replace -----		X X				Fabricate.
0612	Batteries: Battery, storage: Service ----- Test ----- Replace ----- Cable assembly: Replace -----	X X X	X X				Fabricate.
0615	Radio Suppression: Capacitor: Replace -----		X				
11	REAR AXLE.						
1100	Rear Axle Assembly: Axle assembly: Replace -----			X			
18	WHEELS AND TRACKS.						
1811	Wheel Assembly: Hub assembly: Repair ----- Cone and rollers, tapered roller bearing: Service ----- Replace -----		X X X				
1818	Tires, Tubes: Tire, nondirectional and innertube, pneumatic: Service ----- Replace ----- Repair -----	X	X X				
15	FRAME.						
1501	Frame Assembly: Base, cart: Replace ----- Lifting bail: Replace -----			X			
1508	Pintles and Towing Attachments: Tongue: Replace ----- Ring, lunette: Replace -----		X X				
1507	Landing Gear; Leveling Jacks: Foot, cart: Replace -----		X				

Functional group	Components and related operation	Echelons of maintenance					Remarks
		1	2	3	4	5	
22	MISCELLANEOUS BODY, CHASSIS AND ACCESSORY ITEMS.						
2202.1	Mirrors, Reflectors, Personnel Heaters, Defrosters, Wipers, Air Horns: Reflectors, indicator, clearance: Replace -----	--	X				
2210	DATA PLATES AND INSTRUCTION HOLDERS Plate, Identification Replace ----- Plate, Identification (C.O.E.) Replace -----	--	X				
26	ACCESSORIES, PUBLICATIONS, TEST EQUIPMENT AND TOOLS.						
2602.1	Accessories: Chock assembly: Replace -----	--	X				
47	GAGES (NON-ELECTRICAL); WEIGHING AND MEASURING DEVICES.						
4705	Fuel Gages (Quantity): Gage, fuel: Replace -----	--	X				
55	PUMPS (EXCLUDE ENGINE PUMPS).						
5500	Pump Assembly: Pump assembly: Service ----- Inspect ----- Replace ----- Repair -----	X	X				
5501	Volute, Housing: Chamber, pump: Replace -----	--	X				
5502	Impeller; Rotor, Diaphragm: Impeller: Replace -----	--	X				
5504	Discharge Assembly: Elbow, street: Replace -----	--	X				
5504.2	Suction Valve, Suction Heads: Suction flange: Replace ----- Suction head: Adjust ----- Replace -----	--	X				
5505	Lubricators: Cup, grease: Service ----- Replace -----	X	X				

Functional group	Components and related operation	Echelons of maintenance					Remarks
		1	2	3	4	5	
5508.2	Pump Drive Assembly: Seal, bellows shaft: Replace -----		X				
76 7603	FIREFIGHTING EQUIPMENT. Fire Extinguishers: Extinguisher, fire: Replace -----	X					

**APPENDIX III
BASIC ISSUE ITEMS**

Section I. INTRODUCTION

1. General

Section II lists the accessories, tools, and publications required in 1st echelon maintenance and operation, initially issued with, or authorized for the pump.

2. Explanation of Columns

a. Source Codes. The information provided in each column is as follows:

- (1) *Technical Services.* The basic number of the Technical Service assigned supply responsibility for the item is shown. Those spaces with no number shown are Corps of Engineers supply responsibility. Other technical service basic numbers are:

9-Ordnance Corps
10-Quartermaster Corps
11-Signal Corps
12-Adjutant General's Corps

- (2) *Source.* The selection status and methods of supply are indicated by the following code symbols:

(a) P-applied to repair parts which are high mortality parts; procured by technical services, stocked in and supplied from the technical service depot system; and authorized for use at indicated maintenance echelons.

(b) P1-applied to repair parts which are low mortality parts; procured by technical services, stocked only in and supplied from technical service key depots, and authorized for installation at indicated maintenance echelons.

(c) X2--applied to repair parts which are not stocked. The indicated maintenance echelon requiring such repair parts will attempt to obtain from salvage; if not obtainable from salvage, such repair parts will be requisitioned with supporting justification through normal supply channels.

- (8) *Maintenance.* The lowest maintenance echelon authorized to use, stock, install or manufacture the part is indicated by the following code symbol:

O-Organizational Maintenance
(1st and 2d Echelons)

b. Federal Stock Numbers. This column lists the 11-digit Federal stock number which is used for requisitioning purposes.

c. Description.

- (1) The item name and a brief description of the part are shown.

(2) A five-digit Federal supply code for manufacturers and/or other technical services is shown in parentheses followed by the manufacturer's part number. This number will be used for requisitioning purposes when no Federal Stock Number is indicated. *Example:* (08645) 86458

(3) The letters GE, shown in parentheses immediately following the description, indicate General Engineer supply responsibility for the part.

d. Unit of Issue. Where no abbreviation is shown in this column, the unit of issue is "each."

e. Expendability. Those items classified as nonexpendable are indicated by letters NX.

Items not indicated by NX are expendable.

(2) *Item number.* Provides the referenced number for the part shown in the illustration.

f. Quantity Authorized. This column lists the quantities of repair parts, accessories, tools, or publications authorized for issue to the equipment operator or crew as required.

g. Quantity Issued With Equipment. This column lists the quantities of repair parts, accessories, tools, or publications that are initially issued with each item of equipment. Those indicated by an asterisk are to be requisitioned through normal supply channels as required.

h. Illustrations.

(1) *Figure number.* Provide the identifying number of the illustration.

3. Federal Supply Code for Manufacturers

66289--Wisconsin Motor Corp.

4. Comments and Suggestions

Suggestions and recommendations for changes to the Basic Issue Items List will be submitted on DA Form 2028 to The Commanding General, U. S. Army Engineer Maintenance Center, Corps of Engineers, ATTN: EMCDM, P. O. Box 119, Columbus 16, Ohio; Direct communication is authorized.

Section II. BASIC ISSUE ITEMS LIST

Technical service	Source	Code	Recoverability	Federal stock no.	Description	Unit of issue	Expendability	Qty authorized	Qty issued with equipment	Illustrations	
	Source	Maintenance								Fig	Item
	X2	O	--	-----	GROUP 01 ENGINE 0111.1 HANDCRANKING DEVICES CRANK, HAND: (66289) U-212-F	--	--	1	1		
					GROUP 06 ELECTRICAL SYSTEM (ENGINE AND VEHICULAR) 0612 BATTERIES						
11	P	O	--	6140-057-2554	BATTERY, STORAGE: 6 cell, 12 v.	--	NX	2	2		
9	P	O	--	6810-249-9354	SULPHURIC ACID: electrolyte.	gal	--	4	4		
					GROUP 26 ACCESSORIES, PUBLICATIONS, TEST EQUIPMENT AND TOOLS						
					2602.1 ACCESSORIES						
10	P	O	--	7520-559-9618	CASE, MAINTENANCE AND OPERATIONAL MANUALS: cotton duck, water repellent, mildew resistant.	--	--	1	1		
					2602.2 COMMON TOOLS						
10	P	O	--	5120-277-9491	SCREWDRIVER, FLAT TIP: wood handle, flared tip, 1/4 in. w, 4 in. lg blade.	--	--	1	(*)		
10	P	O	--	5120-240-5328	WRENCH, OPEN END, ADJUSTABLE: single head, 15/16 in. jaw opening, 8in. lg.	--	--	1	(*)		
					2602.4 PUBLICATIONS						
12	P	O	--	-----	DEPARTMENT OF THE ARMY OPERATOR AND ORGANIZATIONAL MAINTENANCE MANUAL TM 5-2805-209-12.	--	--	2	2		

Technical Service	Source	Code	Recoverability	Federal stock no.	Description	Unit of issue	Expendability	Qty authorized	Qty issued with equipment	Illustrations	
	Source	Maintenance								Fig	Item
12	--	--	--	-----	DEPARTMENT OF THE ARMY OPERATOR AND ORGANIZATIONAL MAINTENANCE MANUAL TM 5-4320-215-12.	--	--	2	2		
12	--	--	--	-----	DEPARTMENT OF THE ARMY LUBRICA- TION ORDER LO 5-4320-215-12. GROUP 76 FIRE FIGHTING EQUIPMENT 7603 FIRE EXTINGUISHERS	--	--	1	1		
	P1	O	--	4210-639-9594	EXTINGUISHER, FIRE, VAPORIZING LIQUID.	--	--	1	1		
	P1	O	--	4210-555-8837	EXTINGUISHERS, FIRE, MONOBROMOTRI- FLUOROMETHANE: charged, hand shatter- able cylinder, penetrating seal valve, stored pressure, w/bracket, 2.75 lb (HALON-1301) MIL SPEC E-52031 (GE) <i>Note.</i> Requisition CTC/CO ₂ extinguishers until Depot stocks are exhausted.	--	--	1	(*)		
	P1	O	--	4210-708-0031	CYLINDER, CHARGED:	--	--	1	(*)		

INDEX

	Paragraph	Page
Adjustment, voltage regulator:		
Electrical.....	51f	36
Mechanical.....	51e	36
Ammeter and lamp.....	52	45
Battery cables and battery box.....	53	45
Bracket, fire extinguisher and crank holddown.....	59	46
Bromochloromethane type fire extinguisher.....	26	17
Capacities.....	6h	6
Centrifugal pump, grease cup, reducer and nipple, removal and installation.....	44	31
Controls and instruments.....	15	11
Corps of Engineers' Plate.....	6d	5
Crank holddown bracket and fire extinguisher bracket.....	56,59	45-46
Data, tabulated.....	6	4
Demolition:		
By explosive or weapon fire.....	64	51
General.....	62	51
Other methods.....	65	51
To render pumping unit inoperative.....	63	51
Training.....	66	51
Description.....	3	3
Differences in models.....	5	3
Dimensions and weight.....	6g	6
Dismantling for movement.....	13	11
Electrical system:		
Ammeter and clamp.....	52	45
Battery cables and battery box.....	53	45
General.....	48	35
Generator and adjusting support.....	50	36
Generator drive belt and guard.....	49	35
Voltage regulator and shield box.....	51	36
Adjustment.....	51e, 51f	36
Testing.....	51d, 51g	36
Engine:		
Removal and installation.....	45	31
Starting instructions.....	17	11
Stopping instructions.....	18	11
Tabulated data.....	6b	4
Troubleshooting.....	35	29
Equipment:		
Dismantling for movement.....	13	11
Inspection and maintenance in storage.....	70	53
Inspection of new and used.....	9	9
Loading for shipment.....	68	53
Preparation for shipment.....	67	53
Preparation for storage.....	69	53
Reinstallation after movement to a new worksite.....	14	11

Equipment-Continued

	Paragraph	Page
Servicing new and used	12	10
Unloading	7	9
Unpacking new	8	9
Field expedient repairs	40	30
Fire extinguishers:		
Bromochloromethane.....	26	17
Monobromotrifluoromethane	27	17
Fuel and exhaust system:		
Fuel tank and fuel line.....	47	33
General.....	46	33
Generator and adjusting support.....	50	36
Generator drive belt and guard.....	49	35
Grease cup, reducer and nipple:		
Lubrication	55	46
Removal and installation.....	45	31
Identification	4	3
Inspection and maintenance of equipment in storage.....	70	53
Inspection of new and used equipment.....	9	9
Installation of separately packed components.....	10	9
Installation or setting-up instructions.....	11	9
Instruments, controls.....	15	11
Loading equipment for shipment.....	68	53
Lubrication:		
Detailed information.....	29	19
General information	28	19
Lubrication system:		
General.....	54	45
Grease cup, reducer and nipple.....	55	45
Maintenance and operating supplies.....	6f	5
Model, differences.....	5	5
Monobromotrifluoromethane type fire extinguisher.....	27	17
Movement, dismantling	13	11
Operating details.....	19	11
Operation under unusual conditions:		
At high altitudes	25	16
In dusty or sandy areas.....	22	16
In extreme cold ,(below 0°F).....	20	16
In extreme heat.....	21	16
In salt water	24	16
Under rainy or humid conditions.....	23	16
Operation under usual conditions.....	16	11
Operator and organizational maintenance record and report form.....	2	3
Operators daily services.....	31	23
Organizational maintenance.....	32	23
Preparation of equipment:		
For shipment.....	67	53
For storage	69	53
Preventive maintenance services:		
General.....	30	23
Operators daily services.....	31	23
Organizational maintenance.....	32	23
Quarterly.....	33	26

	Paragraph	Page
Pump:		
Fails to deliver	37	30
Fails to prime	36	30
Fails to produce rated capacity.....	38	30
Pressure insufficient.....	39	30
Removal and installation.....	45	31
Tabulated data.....	6c	4
Quarterly preventive maintenance	33	26
Radio interference suppression:		
General methods used to obtain proper suppression.....	41	30
Interference suppression components.....	42	30
Record and report forms	2	8
Reflector, wheel chock, lunette, and lifting bail.....	56,58	45-46
Reinstallation after movement to a new worksite.....	14	11
Removal and installation:		
Centrifugal pump, grease cup, reducer and nipple.....	44	31
Engine	45	31
Repairs, field expedient.....	40	80
Scope	1	3
Servicing new and used equipment.....	12	10
Starting instructions, engine	17	11
Stopping instructions, engine.....	18	11
Storage:		
Inspection and maintenance of equipment.....	70	53
Preparation of equipment.....	69	53
Tabulated data.....	6	4
Testing, voltage regulator:		
After adjustment.....	51g	36
Continuity.....	51d	36
Tires.....	6i	6
Tongue and cart foot.....	56, 57	45
Training, demolition.....	66	51
Troubleshooting:		
Engine	35	29
Field expedient repairs.....	40	30
General.....	34	29
Pump:		
Fails to deliver	37	30
Fails to prime	36	30
Fails to produce rated capacity.....	38	30
Pressure insufficient.....	39	30
Unloading of equipment.....	7	9
Unpacking new equipment.....	8	9
Voltage regulator:		
Adjustment:		
Electrical	51f	36
Mechanical	51e	36
And shield box	51	36
Tabulated data.....	6e	5
Testing after adjustment.....	51g	36
Weight and dimension.....	6g	48
Wheel, tires and tubes	60, 61	48
Wiring diagram	6j	6

BY ORDER OF THE SECRETARY OF THE ARMY:

G. H. DECKER,,
General, United States Army,
Chief of Staff.

OFFICIAL:

R. V. LEE
Major General, United States Army,
The Adjutant General

Distribution:

Active Army:

To be distributed in accordance with DA Form 12-7 requirements for TM 5-series (unclas); plus the following formula:

DCSLOG (1)	
USASA (2)	USAES (100)
CNGB (1)	JBUSMC (1)
Teeth tf, DA (1) except	Units Org under fol TOE:
CofEngrs (8)	5-48 (2)
USAABELCTBD (2)	5-287 (5)
US ARADCOM (2)	5-262 (5)
US8 ARADCOM Rgn (2)	5-267 (1)
MDW (1)	5-278 (5)
Seventh US Army (2)	6-279 (2)
EUSA (2)	5-500 (EA,
Corps (2)	55-500 (FS_
Div (2)	55-557

NG: State AG (3).

USAR: Same as active army except allowance is one copy to each unit.

For explanation of abbreviations used, se AR-320-50.

RECOMMENDED CHANGES TO EQUIPMENT TECHNICAL PUBLICATIONS

 <div style="border: 1px solid black; border-radius: 15px; padding: 5px; display: inline-block; margin-left: 20px;"> <p style="margin: 0;"><i>THEN...JOT DOWN THE DOPE ABOUT IT ON THIS FORM. CAREFULLY TEAR IT OUT, FOLD IT AND DROP IT IN THE MAIL.</i></p> </div>		SOMETHING WRONG WITH PUBLICATION	
		FROM: (PRINT YOUR UNIT'S COMPLETE ADDRESS)	
		DATE SENT	
PUBLICATION NUMBER		PUBLICATION DATE	PUBLICATION TITLE
IN THIS SPACE, TELL WHAT IS WRONG AND WHAT SHOULD BE DONE ABOUT IT.			
BE EXACT PIN-POINT WHERE IT IS			
PAGE NO.	PARA-GRAPH	FIGURE NO.	TABLE NO.
PRINTED NAME, GRADE OR TITLE AND TELEPHONE NUMBER		SIGN HERE	

DA FORM 1 JUL 79 **2028-2**

PREVIOUS EDITIONS ARE OBSOLETE.

P.S.--IF YOUR OUTFIT WANTS TO KNOW ABOUT YOUR RECOMMENDATION MAKE A CARBON COPY OF THIS AND GIVE IT TO YOUR HEADQUARTERS.

The Metric System and Equivalents

Linear Measure

1 centimeter = 10 millimeters = .39 inch
 1 decimeter = 10 centimeters = 3.94 inches
 1 meter = 10 decimeters = 39.37 inches
 1 dekameter = 10 meters = 32.8 feet
 1 hectometer = 10 dekameters = 328.08 feet
 1 kilometer = 10 hectometers = 3,280.8 feet

Weights

1 centigram = 10 milligrams = .15 grain
 1 decigram = 10 centigrams = 1.54 grains
 1 gram = 10 decigrams = .035 ounce
 1 decagram = 10 grams = .35 ounce
 1 hectogram = 10 decagrams = 3.52 ounces
 1 kilogram = 10 hectograms = 2.2 pounds
 1 quintal = 100 kilograms = 220.46 pounds
 1 metric ton = 10 quintals = 1.1 short tons

Liquid Measure

1 centiliter = 10 milliliters = .34 fl. ounce
 1 deciliter = 10 centiliters = 3.38 fl. ounces
 1 liter = 10 deciliters = 33.81 fl. ounces
 1 dekaliter = 10 liters = 2.64 gallons
 1 hectoliter = 10 dekaliters = 26.42 gallons
 1 kiloliter = 10 hectoliters = 264.18 gallons

Square Measure

1 sq. centimeter = 100 sq. millimeters = .155 sq. inch
 1 sq. decimeter = 100 sq. centimeters = 15.5 sq. inches
 1 sq. meter (centare) = 100 sq. decimeters = 10.76 sq. feet
 1 sq. dekameter (are) = 100 sq. meters = 1,076.4 sq. feet
 1 sq. hectometer (hectare) = 100 sq. dekameters = 2.47 acres
 1 sq. kilometer = 100 sq. hectometers = .386 sq. mile

Cubic Measure

1 cu. centimeter = 1000 cu. millimeters = .06 cu. inch
 1 cu. decimeter = 1000 cu. centimeters = 61.02 cu. inches
 1 cu. meter = 1000 cu. decimeters = 35.31 cu. feet

Approximate Conversion Factors

To change	To	Multiply by	To change	To	Multiply by
inches	centimeters	2.540	ounce-inches	Newton-meters	.007062
feet	meters	.305	centimeters	inches	.394
yards	meters	.914	meters	feet	3.280
miles	kilometers	1.609	meters	yards	1.094
square inches	square centimeters	6.451	kilometers	miles	.621
square feet	square meters	.093	square centimeters	square inches	.155
square yards	square meters	.836	square meters	square feet	10.764
square miles	square kilometers	2.590	square meters	square yards	1.196
acres	square hectometers	.405	square kilometers	square miles	.386
cubic feet	cubic meters	.028	square hectometers	acres	2.471
cubic yards	cubic meters	.765	cubic meters	cubic feet	35.315
fluid ounces	milliliters	29.573	cubic meters	cubic yards	1.308
pints	liters	.473	milliliters	fluid ounces	.034
quarts	liters	.946	liters	pints	2.113
gallons	liters	3.785	liters	quarts	1.057
ounces	grams	28.349	liters	gallons	.264
pounds	kilograms	.454	grams	ounces	.035
short tons	metric tons	.907	kilograms	pounds	2.205
pound-feet	Newton-meters	1.356	metric tons	short tons	1.102
pound-inches	Newton-meters	.11296			

Temperature (Exact)

°F	Fahrenheit temperature	5/9 (after subtracting 32)	Celsius temperature	°C
----	------------------------	----------------------------	---------------------	----

PIN: 026874-000